

# Assembly Equipment

## Table of Contents

<b>Index to Crimp Packages</b>	N-2 thru N-3		
<b>Crimping Machines - Portable</b>			
Coll-O-Crimp Portable T-464 & T-466	N-4		
Coll-O-Crimp Portable T-465	N-5 thru N-6		
Coll-O-Crimp T-465 Crimping Procedures	N-7		
Air Conditioning Portable Crimper, T-477	N-8		
T-477 Crimping Procedures	N-9 thru N-12		
Coll-O-Crimp Portable T-480	N-13 thru N-15		
ET1000 Portable Crimp Machine	N-16		
ET1000 Crimp Procedures	N-17		
<b>Crimping Machines - Stationary</b>			
Coll-O-Crimp Shop Press Tooling, T-400-17	N-18		
Coll-O-Crimp I, T-400, T-407	N-19 thru N-20		
Coll-O-Crimp SUPER I, T-420	N-21		
Coll-O-Crimp ET4001	N-22		
T-440, ET4000 & ET4001 Repair Items	N-23		
<b>Crimping Machines - Variable</b>			
Coll-O-Crimp ET4020	N-24		
Coll-O-Crimp ET4040	N-25		
		<b>Tooling and Accessories</b>	
		Coll-O-Crimp Collet Kits	N-26 thru N-29
		WeatherGRIP Tooling	N-30 thru N-31
		Coll-O-Crimp Spacer Rings	N-32
		Coll-O-Crimp Air & Hydraulic Pumps	N-33 thru N-35
		Competitor Conversion Kits	N-36
		Tube Flaring Tools	N-37
		Hose Cutting Equipment	N-38 thru N-40
		Presetting Tools	N-41
		Hose Bore Cleaning Brushes	N-42
		Skiving Tools & Wrenches	N-43
		Power Steering Assembly	N-44 thru N-46
		Cable Controls	N-47 thru N-48
		<b>Assortments</b>	N-49 thru N-67
		<b>Equipment</b>	
		Cabinets, Tool Boxes, and Plastic Bags	N-68 thru N-70
		Label Sets & Mylar Hose Labels	N-71
		Field Attachable Assembly	N-72 thru 73



# Index

## Weatherhead Crimp Machine and Tooling Packages

### Portable Crimpers

Base Machine #	Part Number	Package Contents *	Hose fitting sizes crimped**				Catalog Page
			U-Series	Z-Series	430U	4SP/6SP	
T-465	T-465-HPU	T-465 vice mounted press, hand pump	-4 to -8	-	-	-	N-5
T-460	T-460	T-460 press, hand pump	-	-	-	-	N-4
T-460	T-462	T-462 press, air/hydraulic pump	-	-	-	-	N-4
T-460	T-464	T-460, collets and spacers	-4 to -8	-	-	-	N-4
T-460	T-466	T-462, collets and spacers	-4 to -8	-	-	-	N-4
T-460	ET460TP-0001	Z tooling for -4 to -8	-	-4 to -8	-	-	N-30
T-480	T-480-AH	T-480 press, hand lever air/hydraulic pump	-	-	-	-	N-13
T-480	T-480-HP	T-480 press, hand pump	-	-	-	-	N-13
T-480	T-480-EP	T-480 press, 110v pump	-	-	-	-	N-14
T-480	T-480-TA	T-480 press, foot treadle air/hydraulic pump	-	-	-	-	N-14
T-480	T-480-80	U and 430U tooling for T-480 press	-4 to -16	-	-8 to -20	-	N-28
T-480	ET480-001	T-480-HP press, pump, Z tooling	-	-4 to -16	-	-	N-14
T-480	ET480-002	T-480-AH press, pump, Z tooling	-	-4 to -16	-	-	N-14
T-480	ET480-003	T-480-TA press, pump, Z tooling	-	-4 to -16	-	-	N-14
T-480	ET480-004	T-480-EP press, pump, Z tooling	-	-4 to -16	-	-	N-14
T-480	ET480TP-0001	Z tooling for -4 to -16	-	-4 to -16	-	-	N-30
ET1000	ET1000-001	ET1000 press only	-	-	-	-	N-16
ET1000	ET1000-002	ET1000 press, hand pump	-	-	-	-	N-16
ET1000	ET1000-003	ET1000 press, air/hydraulic pump	-	-	-	-	N-16
ET1000	ET1000-004	ET1000 press, 110v pump	-	-	-	-	N-16
ET1000	ET1000-005	ET1000 press, 12v DC pump	-	-	-	-	N-16
ET1000	ET1000-016	ET1000-002, hand pump, Z tooling	-	-4 to -16	-	-	N-16
ET1000	ET1000-017	ET1000-003, air/hydraulic, Z tooling	-	-4 to -16	-	-	N-16
ET1000	ET1000-018	ET1000-004, 110v pump, Z tooling	-	-4 to -16	-	-	N-16
ET1000	ET1000TP-0001	Z tooling for -4 to -16	-	-4 to -16	-	-	N-30

### Stationary Crimpers: Coll-O-Crimp 1 Series (thru 1-1/4" 2-wire)

Base Machine #	Part Number	Package Contents *	Hose fitting sizes crimped**				Catalog Page
			U-Series	Z-Series	430U	4SP/6SP	
T-400	T-400	T-400-1 press, tooling, (no pump)	-4 to -16	-	-	-	N-19
T-400	T-400-1	T-400-1 press only	-	-	-	-	N-19
T-400	T-401	T-400, 220v 1 phase pump, U tooling	-4 to -16	-	-	-	N-19
T-400	T-401-110	T-400, 110v 1 phase pump, U tooling	-4 to -16	-	-	-	N-19
T-400	T-402	T-400, air/hydraulic pump, U tooling	-4 to -16	-	-	-	N-19
T-400	T-403	T-400, hand pump, U tooling	-4 to -16	-	-	-	N-19
T-400	T-407-1	T-407-1 press only	-	-	-	-	N-20
T-400	T-407	T-407-1, high-volume pump and foot switch	-	-	-	-	N-20
T-400	T-414	T-400, 12v DC pump	-4 to -16	-	-	-	N-19
T-400	ET400-001	T-400-1, 220v 1 phase pump, Z tooling	-	-4 to -16	-	-	N-19
T-400	ET400-002	T-400-1, 110v 1 phase pump, Z tooling	-	-4 to -16	-	-	N-19
T-400	ET400-003	T-400-1, air/hydraulic pump, Z tooling	-	-4 to -16	-	-	N-19
T-400	ET400TP-0001	Z tooling for -4 to -16	-	-4 to -16	-	-	N-30

\* Hose assembly included if pump is included.

\*\* Collets and spacers to crimp fitting size ranges noted are included in packages except -10 size collets/dies typically not included. Check catalog for details.

# Index

## Weatherhead Crimp Machine and Tooling Packages

### Stationary Crimpers: Coll-O-Crimp Super 1 Series (thru 1-1/4" 6-wire)

Base Machine #	Part Number	Package Contents *	Hose fitting sizes crimped**				Catalog Page
			U-Series	Z-Series	430U	4SP/6SP	
T-420	T-420-1	T-420-1 press only	-	-	-	-	N-21
T-420	T-420-N	T-420-1, T-421U 220v pump, U & 430U tooling	-4 to -16	-	-8 to -20	-	N-21
T-420	T-420N-110	T-420-1, T-421U-110 110v pump, U & 430U tooling	-4 to -16	-	-8 to -20	-	N-21
T-420	ET420-002	T-420-1, T-421U 220v pump, Z tooling	-	-4 to -16	-	-	N-21
T-420	ET420-003	T-420-1, T-421U-110 110v pump, Z tooling	-	-4 to -16	-	-	N-21
T-420	ET420-004	T-420-1, T-421U 220v pump, Z & 430U tooling	-	-4 to -16	-8 to -20	-	N-21
T-420	ET420-005	T-420-1, T-421U-110 110v pump, Z & 430U tooling	-	-4 to -16	-8 to -20	-	N-21
T-420	ET420TP-0001	Z tooling for -4 to -16	-	-4 to -16	-	-	N-30

### Stationary Crimpers: Coll-O-Crimp ET4001 (thru 2")

Base Machine #	Part Number	Package Contents *	Hose fitting sizes crimped**				Catalog Page
			U-Series	Z-Series	430U	4SP/6SP	
ET4001	ET4001-002	ET4001 press only (no pump or valve)	-	-	-	-	N-22
ET4001	ET4001-004	ET4001 press, ET4001P-001 220v 1 phase pump	-	-	-	-	N-22
ET4001	ET4001-006	ET4001-004 plus 430U collets	-	-	-8 to -32	-	N-22
ET4001	ET4001-010	ET4001-004 plus 4SP/6SP collets	-	-	-	-12 to -32	N-22
ET4001	ET440TP-0001	Z tooling for -4 to -16	-	-4 to -16	-	-	N-30
ET4001	FF91047	Coll-O-Cart	-	-	-	-	N-23

### Variable Crimpers: ET4020 (thru 1 1/4") and ET4040 (thru 2")

Base Machine #	Part Number	Package Contents *	Hose fitting sizes crimped**				Catalog Page
			U-Series	Z-Series	430U	4SP/6SP	
ET4020	ET4020-115	ET4020 press, 115v pump	-	-	-	-	N-24
ET4020	ET4020-230	ET4020 press, 230v pump	-	-	-	-	N-24
ET4020	ET4020TP-0003	Tooling- full set of die cages	-	-4 to -20	-6 to -20	-	N-24
ET4020	ET4020-006	ET4020-115 plus ET4020TP-003 tooling	-	-4 to -20	-6 to -20	-	N-24
ET4040	ET4040-115	ET4040 press, 115v pump	-	-	-	-	N-25
ET4040	ET4040-230	ET4040 press, 230v pump	-	-	-	-	N-25
ET4040	ET4040TP-0004	Tooling- full set of die cages for Z & 430U	-	-4 to -32	-6 to -32	-	N-25
ET4040	ET4040TP-0005	Tooling- full set of die cages for 4SP/6SP	-	-	-	-12 to -32	N-25
ET4040	ET4040TP-0006	Tooling- full set of die cages for Z & 430U & 4SP/6SP	-	-4 to -32	-6 to -32	-12 to -32	N-25
ET4040	ET4040-007	ET4040-115, ET4040TP-0004, master cage & handle	-	-4 to -32	-6 to -32	-	N-25
ET4040	ET4040-008	ET4040-115, ET4040TP-0005, master cage & handle	-	-	-	-12 to -32	N-25
ET4040	ET4040-009	ET4040-115, ET4040TP-0006, master cage & handle	-	-4 to -32	-6 to -32	-12 to -32	N-25

\* Hose assembly included if pump is included.

\*\* Collets and spacers to crimp fitting size ranges noted are included in packages except -10 size collets/dies typically not included. Check catalog for details.

# Crimping Machines - Portable

Coll-O-Crimp Portable T-464



Refer to pages A-2 and A-3 and machine operator's manuals for safety information.

## T-464 • Portable Coll-O-Crimp w/Hand Pump



The T-460 is a completely portable hose assembly system. Lightweight, hand pump-powered, and complete with a self-supporting base, this crimping press features layback positioning up to a 45° angle.

**Capacity:** 3/16" I.D. 1-fiber braid through 1-3/8" I.D. 1-wire hose and 1-1/4" 2-wire hose.

**Mounting:**  
Free-standing base

**Size:** 15" high, 14" wide, 11-1/4" deep

**Weight:** 62 lbs

For T-460 Tool Box see page N-6.

Reference pages N-2 and N-3 for COC machine and tooling packages, and pages N-26 to N-30 for collet kits and spacer ring details.

Refer to pages A-2 and A-3 and machine operator's manuals for safety information.

## T-464 • Portable Coll-O-Crimp w/Hand Pump Package

Includes one each of the following:

Catalog Number	Description
T-460	Portable Coll-O-Crimp Press, Hand Pump & Hose Assembly Kit, W-EQCR-TM008-E Instructions
T-400-2C	"U" Series Collet – 1/4"
T-400-3C	"U" Series Collet – 3/8"
T-400-4C	"U" Series Collet – 1/2"
T-400-10	Black Spacer Ring
T-400-62	Yellow Spacer Ring

## Repair and Replacement Items

Catalog Number	Description	Catalog Number	Description
W-EQCR-TM008-E	Instructions	T-460-P	Pusher
T-460-SPR	Slide Pull Rod	T-460-SF	Slide Flange
T-460-16	Hose Assembly	T-460-SP	Slide Plate
T-460-2	Hand Pump	T-460-SPK	Slide Pull Knob
W-EQCR-TE009-E	Shroud Decal	E-EQCR-ME002-E	Instructional Video

For replacement pump see page N-33.

## T-466 • Portable Coll-O-Crimp w/Air Hydraulic Pump



This portable Coll-O-Crimp features an air/hydraulic pump making it the ideal system if you have the availability of compressed air in your shop or in the field via a portable compressor.

**Capacity:** 3/16" I.D. 1-fiber braid through 1-3/8" I.D. 1-wire hose and 1-1/4" 2-wire hose.

**Mounting:**  
Free standing base

**Size:** 15" high, 14" wide, 11-1/4" deep

**Weight:** 62 lbs

For T-462 Tool Box see page N-6.

Reference pages N-2 and N-3 for COC machine and tooling packages, and pages N-26 to N-30 for collet kits and spacer ring details.

Refer to pages A-2 and A-3 and machine operator's manuals for safety information.

## T-466 • Portable Coll-O-Crimp w/Air Hydraulic Pump Package

Includes one each of the following:

Catalog Number	Description
T-462	Portable Coll-O-Crimp Press, Air/Hydraulic Pump & Hose Assembly Kit, W-EQCR-TM008-E Instructions
T-400-2C	"U" Series Collet – 1/4"
T-400-3C	"U" Series Collet – 3/8"
T-400-4C	"U" Series Collet – 1/2"
T-400-10	Black Spacer Ring
T-400-62	Yellow Spacer Ring

## Repair and Replacement Items

Catalog Number	Description	Catalog Number	Description
W-EQCR-TM008-E	Instructions	T-460-SPK	Slide Pull Knob
T-460-P	Pusher	T-460-SPR	Slide Pull Rod
T-460-SF	Slide Flange	T-462-16	Hose Assembly
T-460-SP	Slide Plate	T-462-V	Regulator only
W-EQCR-TE010-E	Shroud Decal	T-462-2	Air/Hydraulic Pump
140-06675	Air Regulator Kit	E-EQCR-ME002-E	Instructional Video

For replacement pump see page N-33.



# Crimping Machines - Portable

Coll-O-Crimp Portable T-465

 Refer to pages A-2 and A-3 and machine operator's manuals for safety information.

## Portable Coll-O-Crimp



The Portable Coll-O-Crimp is a completely PORTABLE hose assembly system. NO ELECTRICAL POWER SOURCE IS NEEDED. Hand pump powered, lightweight, vise or stand mounted, this crimper is ideal for your portable crimping needs.

### Capacity

3/16" I.D. 1-fiber braid through 1-3/8" I.D.  
1-wire hose and 1-1/4" 2-wire hose

### Mounting

Vise/Stand

### Size

12-1/2" high, 8-1/2" wide, 5-1/2" deep

### Weight

31 lbs

The vise bracket, die ring, pusher, decal and instruction kit are components of the T-465 Portable Coll-O-Crimp Press.

### Pump Required

(sold separately): T-460-2

### T-465

Portable Coll-O-Crimp Press ONLY

### CAUTION

Use T-460-2 10,000 PSI hand pump only.

### CAUTION

The Coll-O-Crimp power source has the pressure relief valve set at 10,000 PSI. Damage to the press will result if higher pressures are used and warranty will be voided.

Reference pages N-2 and N-3 for COC machine and tooling packages, and pages N-26 to N-30 for collet kits and spacer ring details.

Refer to pages A-2 and A-3 and machine operator's manuals for safety information.

### T-465-HP • Portable Coll-O-Crimp Package Includes one each of the following:

Catalog Number	Description
T-465	Portable Coll-O-Crimp Press
T-460-2	Hand Pump (10,000 PSI)
T-450-3	Quick Disconnect Hose Assembly

For replacement pump see pages N-33-35.

### T-465 HPU • Portable Coll-O-Crimp Package Includes one each of the following:

Catalog Number	Description
T-465-HP	Portable Coll-O-Crimp Package
T-400-2C	"U" Series Collet – 1/4"
T-400-3C	"U" Series Collet – 3/8"
T-400-4C	"U" Series Collet – 1/2"
T-400-10	Black Spacer Ring
T-400-62	Yellow Spacer Ring

# Crimping Machines - Portable

Coll-O-Crimp Portable T-465



Refer to pages A-2 and A-3 and machine operator's manuals for safety information.

## T-450-C • Portable Coll-O-Crimp Stand



The T-450-C Stand is designed specifically for your Portable Coll-O-Crimp T-465 Press. This stand allows you to use your press on a work bench or other flat surface without the need of a vise. Simply bolt the press onto the stand with the supplied bolts, and you're ready to make Coll-O-Crimp Hose Assemblies.

Refer below for repair and replacement items.

## T-465-TB • Portable Coll-O-Crimp Tool Boxes



The T-465-TB tool boxes feature convenient press, pump and collet storage while offering easy mobility of your hose assembly equipment. Supplied as a set, the T-465-TB tool boxes are an excellent addition to the portable Coll-O-Crimp System.

Refer below for repair and replacement items.

### Includes one each:

Catalog Number	Description
T-460-10B	Small Tool Box Stores the T-465 and spacer rings. 15" x 9" x 8".
T-460-10BB	Large Tool Box Stores the T-460-2 and collets. 25" x 10" x 8".

## T-450/T-465 Portable Coll-O-Crimp Repair and Replacement Items

Catalog Number	Description
T-450-D1	Spacer Ring Selector Decal for Nylon Hose (H009, H209, H243, H435, and H436)
T-450-P	Pusher
T-450-Q	Quick Disconnect Coupling
T-450K	Pusher and Retainer Plate Repair Kit. Includes: T-450B Pusher bolt (1) T-450R Retainer plate (1) T-450S Retainer plate screw (2)
W-EQCR-TE011-E	Shroud Decal

# Crimping Machines - Portable

## T-465-1 Crimping Procedure

### WARNING

You must hold the hose assembly in place from below throughout the crimping operation. Do not place fingers or hands at the crimping point during operation. Failure to follow this procedure could result in serious bodily injury.



- Clamp the crimper into a vise or mount to a work bench using the mounting bracket.

#### Note:

Lubricate the tapered cone seat with T-400-G grease or equivalent before any crimping is completed. Continued periodic lubrication is necessary.



- Select proper Coll-O-Crimp hose and end fitting. Insert hose into end fitting, hose is bottomed in end fitting.
- Remove pusher and insert proper size collet halves. Refer to crimp bulletin W-HOOV-TM001-E2.

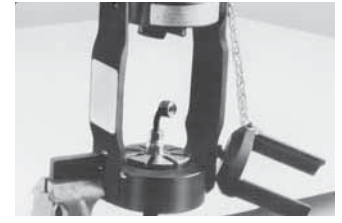

- Insert hose assembly from below between the collet halves. Align the hose end with the top of the collet in the proper location.



- Refer to crimp bulletin W-HOOV-TM001-E2 for proper spacer ring. Place appropriate spacer ring, with the proper orientation, on top of collet. Hold uncrimped hose assembly in place throughout crimping operation.



1. Replace pusher by hanging it from ramplate with bolt on top. Slide it back for centering. Close valve on hand pump and start pumping to crimp.



- When spacer ring contacts die ring, the crimp is complete. Open valve on hand pump. Allow the ram and pusher to retract.
- Remove pusher and spacer ring. Remove crimped assembly from below through the collet halves. Visually inspect the crimped end.
- To ensure a proper crimp has been completed, measure the nominal crimp diameter and verify the proper crimp length and crimp location. Refer to crimp bulletin W-HOOV-TM001-E2.

# Crimping Machines - Portable

Air Conditioning Portable T-477

 Refer to pages A-2 and A-3 and machine operator's manuals for safety information.

## T-477-1 • Portable Air Conditioning Press



This hand operated, lightweight and easy-to-use air conditioning press is engineered and designed specifically for use with Weatherhead 757 "E" series hose end fittings. Perfect for bench mounting this portable press is made of heavy-duty construction for use with an air-impact wrench. Uses color-coded urethane-encased

dies and a removable die holder to accommodate complicated shapes. Uses four standard die sizes (#6, #8, #10, and #12) that produce an OE-style triple-bubble crimp. No electrical requirements necessary.

**Capacity:** Crimps 2-braid dimension nylon barrier or reduced-diameter hose.

### Mounting:

Bench or mount in vise

**Weight:** 6 lbs.

Reference pages N-2 and N-3 for COC machine and tooling packages, and pages N-26 to N-30 for collet kits and spacer ring details.

Refer to pages A-2 and A-3 and machine operator's manuals for safety information.

## T-477 • Portable Air Conditioning Package



### Package includes:

Part Number	Description
T-477-1	Portable A/C Press
T-477-105C	#6 Die Set - Red
T-477-106C	#8 Die Set - Black
T-477-107C	#10 Die Set - Almond
T-477-108C	#12 Die Set - Green

Includes Bench Mount Flange, Die Set Lubricant and Steel Pipe Nipple Extension. Also includes a Custom Carrying Case with Instructions.



# Crimping Machines - Portable

T-477-1 Crimping Procedure

 Refer to pages A-2 and A-3 and machine operator's manuals for safety information.

## T-477-1 Crimp Die Sets

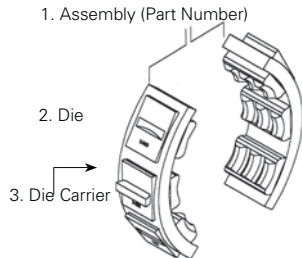

## T-477-1 Die Set Information

Item	Description	Quantity	6	8	10	12
1	Assembly Part Number	1 set	T-477-105C	T-477-106C	T-477-107C	T-477-108C
2	Die Marking	-	6R556	8R655	10R742	12R897
3	Die Carrier Color	-	Red	Black	Almond	Green

For use with H757 Hose and 757 "E" Series Hose Ends.

## T-477-1 Crimper Parts List

When ordering T-477-1 spare parts, contact: [www.atcoproductsinc.com](http://www.atcoproductsinc.com) or Email: [info@atcomail.com](mailto:info@atcomail.com) or call: 1-972-842-8178.

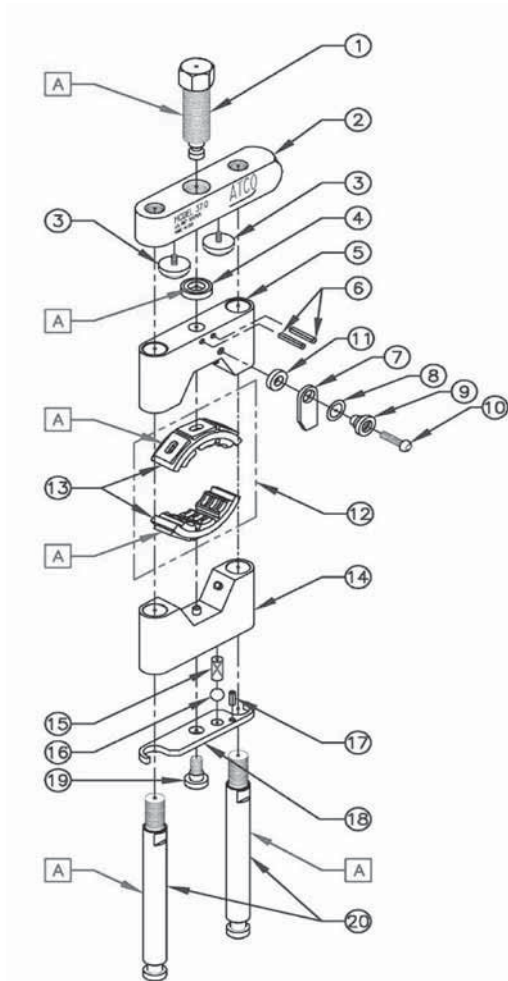

## Parts List

Item	Description	Qty	Part No.
1	Actuator Screw	1	75013
2	Actuator Bar	1	75177
3	Rubber Bumper	2	75012
4	Thrust Bushing	1	75149
5	Movable Die Holder	1	75175
6	3/16 x 1 Roll Pin	2	75010
7	Locator Flag*	1	75086-Y
8	Curved Disc Spring	1	75088
9	Locator Bushing	1	75087-Y
10	1/4-20 x 1 Button Head Screw*	1	75113
11	Spacer Bushing	7	75176
12	See Crimp Die List	1	See Item 1 (top)‡
13	Crimp Die Carrier	1	See Item 1 (top)‡
14	Removable Die Holder**	1	75174
15	Spring-Compression**	1	75076
16	7/16 Diameter Ball**	1	75077
17	3/16 x 1/2 Roll Pin**	1	75009
18	Latch Plate	1	75074
19	Lock Screw**	1	75008
20	Strain Rod	2	75020

‡ References Item 1 in Die Set Chart at the top of the page.

## Items Not Shown

Item	Description	Qty	Part No.
A	Grease	1	75015
B	3/8 x 4 Pipe Nipple	1	75016
C	3/8 Flooring Flange	1	90607
D	Carrying Case	1	75017

\* Included in item 24 (Not assembled) / \*\* Included in item 25 (Assembled).

## For use with H757 Hose and 757 "E" Series Hose Ends

Item	Description	Qty	6	8	10	12
-	Die Marking	-	6R556	8R655	10R742	12R897
26	Crimp Die No.	1 set	T-475-105C	T-475-106C	T-475-107C	T-475-108C
-	Color	-	Red	Black	Almond	Green
16	Die Carrier	2	75140	71688	75136	71690
15	Die Segment	6	71741	75119	71743	71744

# Crimping Machines - Portable

T-477-1 Crimping Procedure

## Model T-477 Portable Air Conditioning Hose Crimping Kit

### Description of terms

The crimper can be operated with a 1/2" drive air impact wrench, ratchet or breaker bar. It takes approximately 100 foot pounds of torque to fully close the jaws and achieve a satisfactory crimp. The crimper can be bench mounted using the flange and pipe nipple provided or it can be mounted in a bench vise to stabilize the unit. If the unit is used in a service vehicle with a mounted vice, it will be necessary to use a 12" minimum extension to the pipe nipple to counteract the torque while closing the dies. This extension is not provided in the kit.

**Bench mount:** Bolt the flange to a bench top. Screw the pipe nipple and crimper to the flange plate.

**Impact wrench (1/2" Drive @ 100 PSIG Max.):** Use a 1" impact socket to drive the movable die holder.

### ⚠ CAUTION

Do not exceed 100 PSIG air pressure on the impact wrench as damage to the wrench and the crimper may result.

### ⚠ CAUTION

Do not continue impacting after the dies are closed. This can cause damage to the crimper.

### ⚠ CAUTION

Care should be taken when reversing the impact so that the die holder does not slam into the crimper body (actuator bar, Item 2). Bumpers are provided to minimize damage.

### Ratchet or breaker bar:

Use a 1" socket to drive the movable die holder. It will take approximately 100 foot pounds of torque to achieve a full crimp.

### Removable die holder:

The bottom of the crimper can be removed to accommodate special shapes or under-hood crimping. Push the latch plate (Item 21) open while holding the removable die holder. Pull the holder off the strain rods.

**Die change:** With the removable die holder removed, loosen two of the button head screws (Item 12) on one side of the die holder. The die will drop out of the holder. Apply grease (Item B) to the slide surfaces. Squeeze the outer segments of the die set together and insert the die into the holder making sure that the Woodruff Key (Item 14) in the center segment snaps fully into the groove in the holder (Refer to Fig. 1).

While holding the die securely in the slot, retighten the two button head screws. Check to make sure that the two outer segments on each half are free to move. If they do not move freely, remove and inspect for damaged guide block pad or dirt.

### ⚠ CAUTION

Retention of the Woodruff Key in the slot while tightening the screws is most important. Failure to do so will result in an irregular crimp and damage to the guide blocks and Woodruff Key (Refer to Fig. 2).

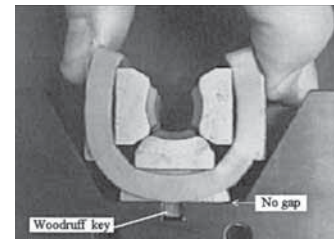
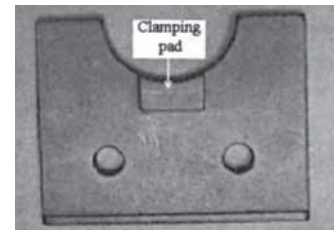

Figure 1

Die carrier properly inserted in holder.



Undamaged Pad

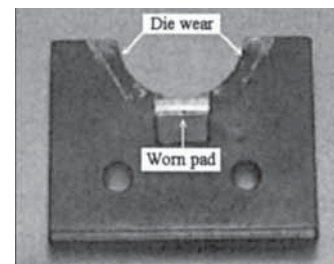

Figure 2

Damaged Pad

# Crimping Machines - Portable

T-477-1 Crimping Procedure

**!** Refer to pages A-2 and A-3 and machine operator's manuals for safety information.

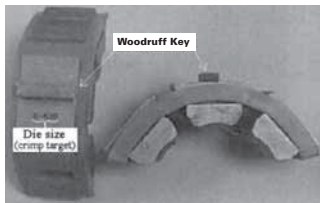
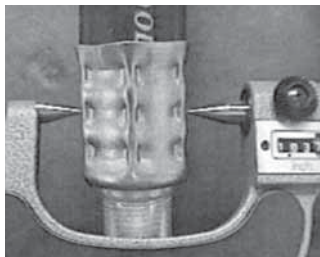

**Figure 3**

Dies with Woodruff Keys in place



Position of tip of micrometer



**Figure 4**

Measuring the crimp with a micrometer

**!** **CAUTION**

It is not necessary to over-tighten the screws. Always use the short hex key wrench provided in order to avoid damage.

**Die Carrier**

The die carriers will become worn and produce unacceptable crimps with time. To replace the color-coded die carriers, simply push the die segment out of the back of the carrier. Reverse the process to assemble die segments in the new carrier.

**Woodruff Key**

The Woodruff Key is bonded into the slot in the center die segment. It is used to align the dies in the die holders (Refer to Fig. 3).

**!** **CAUTION**

If the Woodruff Key is not in the center segment of each half of the die set, an irregular crimp will be formed increasing the probability of leakage.

**!** **CAUTION**

Never use dies without Woodruff Key engaged in the slot of the segment and holder.

To replace the Woodruff Key, use a screwdriver and hammer to remove the old key. Replace the key using a drop of adhesive such as Loctite® to hold the key securely.

**Locator Flag**

There is a locator flag on the crimper. It is spring loaded and movable to locate the end of the ferrule for proper crimp location. Swivel the flag to a position so that when the fitting is inserted into the crimper, the ferrule will stop in the proper location for crimping.

**Crimp diameter measurement**

The crimp diameter can be measured by using a set of point micrometers or calipers with a point accessory kit installed. Standard measuring instruments will not reach to the crimp impression because of the pinch of the crimp. When measuring the crimp diameter, take three measurements around the center crimp ring. Add the measurements, divide by three to get the average. The average should be the target crimp diameter (+.015/-.005). Example: The #6 size is .556 target crimp diameter. The crimp should measure between .571 and .551 (Refer to Fig 4).

**Hose Wall Thickness**

The hose wall thicknesses for one-braid dimension hoses are listed below. It is important to check the hose wall thickness to make sure that the crimp will be leak free.

Hose size	Hose O.D.
#6 - 5/16 I.D.	9/16
#8 - 13/32 I.D.	11/16
#10 - 1/2 I.D.	3/4
#12 - 5/8 I.D.	15/16

**Operation**

- Mount the crimper as described previously unless it is necessary to mount it in the vice on the service vehicle.
- Select the proper size dies. Check all segments to make sure that all of the segments have the same numbers on the back. Each segment will be marked identifying the hose size and crimp diameter. Example: 5/16 ID hose with a .556 diameter crimp will be marked "556" (Refer to Fig. 3).
- Lubricate the slides of the crimper die holders (Items 5 and 17) and the screw thread (Item 1) with an appropriate grease (Item B).
- Refer to die change outlined above for proper assembly of the dies into the crimper.
- Position the locator flag (Item 8) so the ferrule of the fitting bumps it on the side when inserted into the crimper.

**!** **CAUTION**

Do not locate from the bead on the fitting. This will result in the wrong crimp location.

- Insert the hose into the fitting making sure that the hose appears in the small inspection hole on the side or end of the ferrule.

**!** **CAUTION**

If the hose does not appear in the inspection hole, a poor crimp may result.

Loctite® is a registered trademark of Loctite Corporation.

# Crimping Machines - Portable

T-477-1 Crimping Procedure

**!** Refer to pages A-2 and A-3 and machine operator's manuals for safety information.

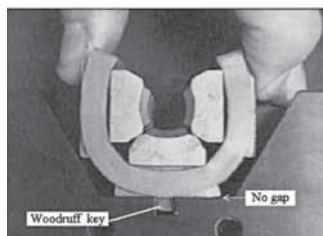

**Figure 5**

Crimp head completely closed.

\*Refer to T-477-1 Crimper Parts List, page N-4.

- Place the assembly into the crimper and hold it against the locator flag. Only the ferrule should touch the flag. Operate the screw (Item 1) to close the dies to the full closed position. This will provide the proper compression to achieve a leak-free crimp. When the crimp dies are bottomed out, there will be a slight gap between the two die holders. This ensures that the dies are fully closed before the holders bottom out (Refer to Fig. 5).
- Reverse the screw (Item 1) to release the crimper from the hose assembly. Take care not to drive the die holder (Item 5) against the actuator bar (Item 2) as damage to the crimper may result. The bumpers (Item 3) are provided as a cushion to help prevent this from occurring.
- If the crimp is performed under-hood or the fitting is a complicated shape that requires disassembly of the crimper, open the latch plate (Item 18) and remove the die holder (Item 14).
- Inspect the first crimp to make sure that the correct dies were used, the crimp location is correct, the crimp is uniform and there is no internal deformation of the fitting.

**Note:**  
See page N-9 for item references.

**Note:**  
Some hose materials trap air in the hose layers during manufacture. When leak testing a newly pressurized hose using soap bubbles or water submersion, the air in the hose will bleed out at the fitting and hose interface indicating a false leaking condition. Leave the hose pressurized for one hour and retest. The residual air should completely bleed out and no leak will be visible.

## Crimper Maintenance

- Clean and lubricate all moving parts. Use an appropriate grease (Item B) as needed when lubricating.
- Inspect the strain rods and latch plate for wear around the contact points.
- Make sure the actuator screw turns freely. Lubricate as noted above.
- Check for worn or torn die carriers. Replace when crimp appears to go out of round.
- Inspect Woodruff Keys. Replace if they are damaged or missing to ensure good crimps.

## Troubleshooting

Problem	Cause	Action
1. Oblong or irregular crimp	<ul style="list-style-type: none"> <li>Worn carriers</li> <li>One die segment in the set is the wrong size</li> <li>Woodruff Key missing</li> <li>Guide blocks installed backwards</li> </ul>	<ul style="list-style-type: none"> <li>Replace carriers</li> <li>Check all segments for correct size on back of die</li> <li>Replace key</li> <li>Turn guide blocks around so raised pad clamps on die</li> </ul>
2. Crimp diameter too large	<ul style="list-style-type: none"> <li>Crimper not fully closed – refer to instructions</li> <li>Incorrect size dies</li> </ul>	<ul style="list-style-type: none"> <li>Recrimp until dies fully close</li> <li>Replace with correct size</li> </ul>
3. Crimp diameter too small	<ul style="list-style-type: none"> <li>Incorrect size dies</li> </ul>	<ul style="list-style-type: none"> <li>Replace with correct size</li> </ul>
4. Crimp location too close to closed end of ferrule	<ul style="list-style-type: none"> <li>Ferrule not inserted far enough into crimper</li> </ul>	<ul style="list-style-type: none"> <li>Use locator flag to properly locate ferrule position</li> </ul>
5. Crimp location too close to hose	<ul style="list-style-type: none"> <li>Ferrule inserted too far into crimper (past locator flag)</li> </ul>	<ul style="list-style-type: none"> <li>Use locator flag to properly locate ferrule position</li> </ul>
6. Crimped fitting leaks when tested with soap bubbles	<ul style="list-style-type: none"> <li>Air trapped in the hose during manufacture</li> <li>Insufficient crimp</li> <li>Hose wall thickness is undersize (see chart)</li> <li>Fitting is defective</li> </ul>	<ul style="list-style-type: none"> <li>Recheck after system has been charged for one hour – air will bleed out of the hose</li> <li>Check crimp diameter</li> <li>Recrimp with .030 undersize die</li> <li>Replace fitting/recrimp</li> </ul>
7. Crimped fitting leaks when tested with electronic leak detector	<ul style="list-style-type: none"> <li>Insufficient crimp</li> <li>Hose wall thickness</li> </ul>	<ul style="list-style-type: none"> <li>Check crimp diameter</li> <li>Recrimp with .030</li> </ul>

# Crimping Machines - Portable

Coll-O-Crimp Portable T-480



Refer to pages A-2 and A-3 and machine operator's manuals for safety information.

## T-480-HP • Portable Coll-O-Crimp Press & Hand Pump Package



Reference pages N-2 and N-3 for COC machine and tooling packages, and pages N-26 to N-30 for collet kits and spacer ring details.

Refer to pages A-2 and A-3 and machine operator's manuals for safety information.

Make factory-type hose assemblies anywhere-anytime! Versatile and portable, this package offers the ease of use you are looking for in a Coll-O-Crimp hose assembly system. The T-480 Coll-O-Crimp Press packages are offered in four options. Listed below are press/power unit packages.

For cabinets see pages N-68-70 (not included).

### Capacity

3/16" I.D. 1 fiber braid through 1-1/4" I.D. 6 spiral hose

### Mounting

Free Standing Base

### Size

22-1/2" high, 14" long, 10-1/2" wide

### Total Weight

112 lbs.

## T-480-2 Pump Specifications:

### Dimensions

7-3/16" high, 21-1/64" long, 4-3/4" wide

### Pressure

0-10,000 psi

### Outlet Port Size

3/8" NPT

### Hydraulic Oil

Enerpac

### Reservoir Capacity

55 cu. in.

Includes **T-480-68** blue pusher extension ring to be used with **T-480** Portable Coll-O-Crimp and the **T-420** and **ET420** collets only.

For replacement pump see pages N-33-35.

## T-480-AH • Portable Coll-O-Crimp Press & Air/Hydraulic Pump Package

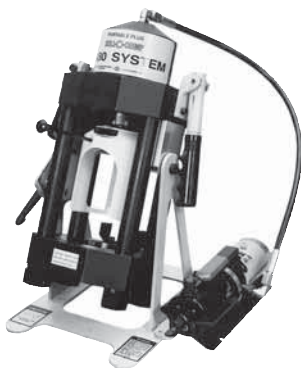

Reference pages N-2 and N-3 for COC machine and tooling packages, and pages N-26 to N-30 for collet kits and spacer ring details.

Refer to safety information regarding Coll-O-Crimp crimping procedures on pages N-4-17.

### Capacity

3/16" I.D. 1 fiber braid through 1-1/4" I.D. 6 spiral hose

### Mounting

Free Standing Base

### Size

22-1/2" high, 14" long, 10-1/2" wide

### Total Weight

124 lbs.

T-482-2 Pump Specifications:

### Dimensions

5" high, 14-5/8" long, 5-5/8" wide

### Pressure

0-10,000 psi

### Outlet Port Size

3/8" NPT

### Inlet Port

1/4" NPT

### Pump Inlet Air Pressure

60-100 psi

### Hydraulic Oil

Enerpac

### Reservoir Capacity

36 cu. in.

Includes **T-480-68** blue pusher extension ring to be used with **T-480** Portable Coll-O-Crimp and the **T-420** and **ET420** collets only.

**Note:** It is recommended that a filter, regulator, lubricator, and air pressure gauge be installed upstream from the pump. Filter, regulator, and lubricator units are not included.

For replacement pump see pages N-33-35.



# Crimping Machines - Portable

Coll-O-Crimp Portable T-480



Refer to pages A-2 and A-3 and machine operator's manuals for safety information.

## T-480-TA Portable Coll-O-Crimp Press and Turbo Air/Hydraulic Pump Package



Reference pages N-2 and N-3 for COC machine and tooling packages, and pages N-26 to N-30 for collet kits and spacer ring details.

Refer to pages A-2 and A-3 and machine operator's manuals for safety information.

**Capacity**  
3/16" I.D. 1 fiber braid through 1-1/4" I.D. 6 spiral hose

**Mounting**  
Free Standing Base

**Size**  
22-1/2" high, 14" long, 10-1/2" wide

**Total Weight**  
116 lbs.

T-480-3 Pump Specifications:

**Dimensions**  
8-1/4" high, 12-3/8" long, 8" wide

**Pressure**  
0-10,000 psi

**Outlet Port Size**  
3/8" NPT

**Inlet Port**  
1/4" NPT

**Pump Inlet Air Pressure:**  
40-150 psi

**Hydraulic Oil**  
Enerpac

**Reservoir Capacity**  
150 cu. in.

Includes **T-480-68** blue pusher extension ring to be used with **T-480** Portable Coll-O-Crimp and the **T-420** and **ET420** collets only.

**Note:** It is recommended that a filter, regulator, lubricator, and air pressure gauge be installed upstream from the pump. Filter, regulator, and lubricator units are not included.

For replacement pump see pages N-33-35.

## T-480-EP Portable Coll-O-Crimp Press and 110v Electric Pump Package



Reference pages N-2 and N-3 for COC machine and tooling packages, and pages N-26 to N-30 for collet kits and spacer ring details.

Refer to pages A-2 and A-3 and machine operator's manuals for safety information.

**Capacity**  
3/16" I.D. 1 fiber braid through 1-1/4" I.D. 6 spiral hose

**Mounting**  
Free Standing Base

**Size**  
22-1/2" high, 14" long, 10-1/2" wide

**Total Weight**  
134 lbs.

T-481-110 Pump Specifications:

**Electrical Power Source**  
15amp, 110v grounded 1Ph 50/60HZ

**Dimensions**  
14-1/4" high, 9-5/8" long, 9-5/8" wide

**Pressure**  
0-10,000 psi

**Outlet Port Size**  
3/8" NPT

**Hydraulic Oil**  
Enerpac

**Reservoir Capacity**  
115.5 cu. in.

**Flow**  
.5 to 1.0 gpm

**Motor Rating**  
1/2 hp universal, 9 amps at 10,000 psi

Includes **T-480-68** blue pusher extension ring to be used with **T-480** Portable Coll-O-Crimp and the **T-420** and **ET420** collets only.

For replacement pump see pages N-33-35.

Package #	ET480-001	ET480-002	ET480-003	ET480-004
Power source	Hand pump	Air/Hydraulic (Hand Switch)	Turbo Air/Hydraulic (Foot Pedal)	110V
<b>Contents</b>				
Press, Pump and Hose Assembly	T-480-HP	T-480-AH	T-480-TA	T-480-EP
Adapter Ring	T-420-25	T-420-25	T-420-25	T-420-25
Z-series tooling for -4 thru -16 (no -10) one wire and two wire	ET480TP-0001	ET480TP-0001	ET480TP-0001	ET480TP-0001

See pages N-26-32 for a breakdown of collets and spacer rings included in these packages.

# Crimping Machines - Portable

Coll-O-Crimp Portable T-480



Refer to pages A-2 and A-3 and machine operator's manuals for safety information.

## T-480 • Portable Coll-O-Crimp Repair and Replacement Items

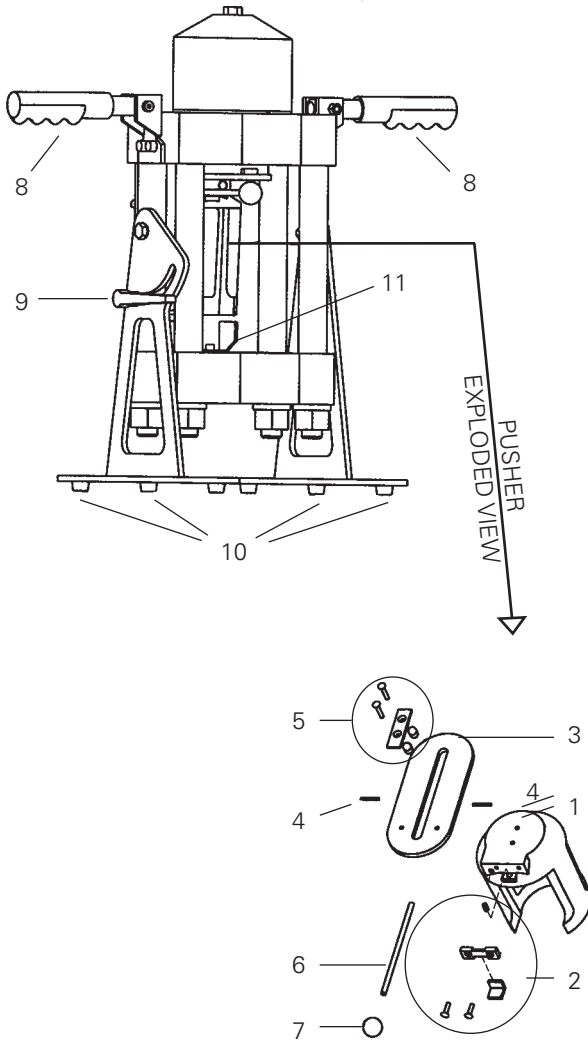

Item Number	Catalog Number	Description
1	T-480-P	Pusher
2	T-480-PSK	Pusher Stop Repair Kit (Includes pusher clip, 2 machine screws, pusher stop and spring)
3	T-480-SP	Slider Plate
4	140-05485-01	Roll Pin
5	T-480-SFK	Slide Flange Kit (Includes slide flange, 2 bushings and 2 machine screws)
6	T-480-SPR	Slide Pull Rod
7	T-480-SPK	Slide Pull Knob
8	140-06601	Vinyl Grip
9	T-480-TBK	Tilt Bracket Knob
10	140-06894	Foot Pad
11	T-480-69	Tool Locator Bracket
#	T-480-16	10,000 PSI replacement hose assembly for 480-HP
#	T-480-17	10,000 PSI replacement hose assembly for T-480-TA and T-480-EP
#	T-480-18	10,000 PSI replacement hose assembly for 480-AH
#	140-06906	Hydraulic Quick Coupler used with the T-480-TA and T-480-EP System
#	T-480-3	Turbo Air/Hydraulic replacement pump for T-480-TA System
#	T-481-110	Electric replacement pump for T-480-EP System
#	T-480-2	Hand replacement pump for T-480-HP System
#	T-482-2	Air/Hydraulic replacement pump for T-480-AH System
#	W-EQCR-TE012-E	Shroud Decal
#	W-EQCR-TM013-E	Set-up and Operating Guide for T-480 System
#	E-EQCR-ME002-E	Instructional Video

# Item not illustrated in parts breakdown.

# Crimping Machines - Portable

## ET1000 Portable Crimp Machine

### ET1000 • Portable Crimp Machine

#### CAUTION

Refer to pages A-2 and A-3 and machine operator's manuals for safety information.



The completely PORTABLE ET1000 crimp machine boasts a broad crimp capability with an ease-of-use that is sure to please hose assemblers. With three power source options - air/hydraulic, hand, and electric - this portable machine can travel to the worksite. The machine comes equipped with a stand pre-drilled for mounting to a workbench or table-top.

The ET1000 Portable Crimp Machine is a mid-size machine positioned between the other two popular portable crimp machines (the T-460 and T-480).

#### Capacity

Coll-O-Crimp U series hose ends and applicable hoses in sizes 1/4" through 1-1/4"

Coll-O-Crimp Z Series hose ends and applicable hoses in sizes 1/4" through 1-1/4"

Coll-O-Crimp 430U Series hose ends and applicable hoses in sizes 3/8" through 3/4"

#### Mounting

Work bench or table top

#### Weight

70 lbs. (less pump)

#### Tooling

Standard Coll-O-Crimp collets and spacer rings. Uses the same tooling as the T-420 machine.

#### Pump Kits

(pump kits contain hose assembly and fittings to attach pump to machine)

**ET1000PK-001**  
Hand Pump

**ET1000PK-002,**  
Air/Hydraulic Pump

**ET1000PK-003**  
110 Volt Electric Pump

#### Pump Only

(does not include hose assembly or fittings)

**T-480-2**  
Hand Pump

**T-482-2**  
Air/Hydraulic Pump

**T-481-110**  
110 Volt Electric Pump

#### Ordering Options

ET1000-001	Basic machine (no pump)
ET1000-002	Machine with hand pump*
ET1000-003	Machine with air/hydraulic pump*
ET1000-004	Machine with 110 volt electric pump*

\* Includes hose assembly and fittings to attach pump to machine.

**Note:** Collets and spacers not included in kits. Must be ordered separately. See pages N-26-32 for part numbers.

**Note:** ET1000AR-001 adapter die ring required to Crimp T-400 and ET400 series collets. Not included in kits and must be ordered separately.

#### Repair and replacement items

ET1000C-0001	Stand
ET1000C-0006	Pusher
ET1000AR-001	Adapter Ring
T-400-G	1.5 oz. Tube High Efficiency Teflon® Grease

Additional repair and replacement items are available. Refer to the owner's manual or contact Eaton for information.

Teflon® is a registered trademark of DuPont used under license by Eaton.

#### ET1000 • Portable Coll-O-Crimp Packages for Z-Series

-4 thru -16 (no -10), one-wire and two-wire

Package Number	ET1000-016	ET1000-017	ET1000-018
Power Source	Hand Pump	Air/Hydraulic	110V
Contents Press, Pump and Hose Assembly	ET1000-002	ET1000-003	ET1000-004
Adapter Ring	ET1000AR-001	ET1000AR-001	ET1000AR-001
Z-Series Collets*	ET1000TP-0001	ET1000TP-0001	ET1000TP-0001

\* See page N-30

# Crimping Machines - Portable

ET1000 Crimping Procedures

## Note:

See Crimp Bulletin #W-HOOV-TM001-E2 for tooling specifications.

## Crimping Procedures



### Step 1

Slide the pusher to the back position.

Using the Collet/Spacer Ring Selector Chart, select the proper collet assembly and spacer ring.

### Step 2A (for T-420 and ET420 Series Collets)

Lubricate the inside cone of the die ring and external surfaces of the collet assembly with a high-efficiency Teflon-based lubricant (T-400-G).

Insert the collet assembly into the base die ring.

### Step 2B (for T-400 and ET400 Series Collets)

Lubricate the inside cone of the base die ring and the outside cone of the die ring adapter plate.

Place the die ring adapter plate into the base die ring.

Lubricate the external surfaces of collet assembly halves with a high-efficiency Teflon-based lubricant.

Insert the collet assembly into the die ring adapter plate.



### Step 3

Insert the hose assembly through the bottom of the base die ring and between the two collet assembly halves. Align the fitting with the top of the collet halves as referenced on the Collet/Spacer Ring Selector Chart.



### Step 4

Place the spacer ring in the appropriate position on top of the collet assembly (either flat-side up or flat-side down as referenced in the Collet/Spacer Ring Selector Chart).



### Step 5

Pull the pusher forward into the detent holding position with the pusher positioning handle.

### Step 6

Begin crimping by actuating the pump. **When the spacer ring bottoms out against the base die ring,** the crimping is complete.

#### Note:

Visually inspect the crimp and verify the correct crimp diameter and length.

Teflon® is a registered trademark of DuPont used under license by Eaton.

# Crimping Machines - Stationary

Coll-O-Crimp T-400-17

 Refer to pages A-2 and A-3 and machine operator's manuals for safety information.

## Shop Press Tooling Packages

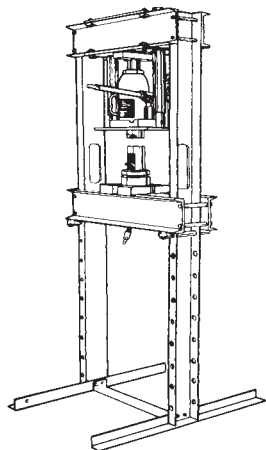

### T-400-17 • Shop Press Tooling Package

The T-400-17 Shop Press Tooling Kit allows you to make factory-type hydraulic hose assemblies on your 25-ton shop press. With this minimum investment in equipment, and a nominal stock of packaged bulk hose and hose ends, you can begin to make Coll-O-Crimp hose assemblies in your own shop. This kit includes tooling to crimp 1/4" through 1" hose I.D. "U" Series hose ends. Additional tooling is available to crimp 5/8" and 1-1/4" I.D. sizes.

#### Included in kit:

Part Number	Description
T-400-2C	"U" Series Collet – 1/4"
T-400-3C	"U" Series Collet – 3/8"
T-400-4C	"U" Series Collet – 1/2"
T-400-5C	"U" Series Collet – 3/4"
T-400-6C	"U" Series Collet – 1"
T-400-8	Die Ring – 3/16" thru 1-1/4"
T-400-10	Spacer Ring – Black
T-400-11	Spacer Ring – Silver
T-400-17P	Pusher
W-EQCR-TD003-E	Shroud Decal
T-400-MSP	Instructions

## WARNING

These kits are intended for use on shop presses not exceeding a 25-ton rating. Usage of presses exceeding this rating may result in damage to the pusher, causing metal fragments to spray which may result in serious bodily injury.

### T-400-20A • Shop Press 757 "E" Series Tooling Package

The T-400-20A Shop Press 757 "E" Series Tooling Kit allows you to make factory-type air conditioning hose assemblies on your 25-ton shop press. With this minimum investment in equipment, and a nominal stock of packaged bulk hose and hose ends, you can begin to make Coll-O-Crimp hose assemblies in your own shop. This kit includes tooling to crimp all of the 757 'E' Series hose ends.

#### Included in kit:

Part Number	Description
T-400-114	757 "E" Series Collets
T-400-8	Die Ring Fits Collets 3/16" thru 1-1/4"
T-400-10	Spacer Ring – Black
T-400-17P	Pusher
W-EQCR-TD003-E	Shroud Decal
FS-3200	Label Set

Reference pages N-2 and N-3 for COC machine and tooling packages, and pages N-26 to N-30 for collet kits and spacer ring details.



# Crimping Machines - Stationary

Coll-O-Crimp T-400



Refer to pages A-2 and A-3 and machine operator's manuals for safety information.

## Coll-O-Crimp T-400



The Coll-O-Crimp I is the time-proven "Mini-Factory" that you can easily set up in your own shop. Fast, easy, compact, and various power sources available make this crimper versatile for even the smallest of workshops.

### Capacity

3/16" I.D. 1-fiber braid through 1-3/8" I.D. 1 wire hose and 1-1/4" I.D. 2 wire hose

### Mounting

Bench; FH-135X or C40X Cabinet

For cabinets see pages N-68-70

### Size

16-1/4" high, 8" wide, 21-3/4" deep

### Weight

113 lbs

Packages continued on next page.

Reference pages N-2 and N-3 for COC machine and tooling packages, and pages N-26 to N-30 for collet kits and spacer ring details.

### Note:

25 ton (T-400-1 is C-O-C press only)

## T-400 • Coll-O-Crimp I Packages for Z-Series

-4 thru -16 (no -10), one-wire and two-wire

Package Number	ET400-001	ET400-002	ET400-003
Power Source	220V	110V	Air/Hydraulic
Press	T-400-1	T-400-1	T-400-1
Hose Assembly	T-400-16	T-400-16	T-400-18
Pump	T-421U	T-421U-110	T-402-2
Die Ring	T-400-8	T-400-8	T-400-8
Z-Series Collets*	ET400TP-0001	ET400TP-0001	ET400TP-0001

\* See page N-30 for details.

## T-401 • C-O-C I and 220v Electric Pump Package

Includes one each of the following:

Catalog Number	Description
T-400	Press and tooling package
T-421U	Electric Pump (220v, 1 phase)

## T-401-110 • C-O-C I and 110v Electric Pump Package

Includes one each of the following:

Catalog Number	Description
T-400	Press and tooling package
T-421U-110	Electric Pump (110v, 1 phase)

## T-400 • Coll-O-Crimp I Package for U-Series\*

Includes one each of the following:

Catalog Number	Description
T-400-1	Coll-O-Crimp Press, T-400-BB Switch, and T-400-M Instructions
T-400-2C	"U" Series Collet – 1/4"
T-400-3C	"U" Series Collet – 3/8"
T-400-4C	"U" Series Collet – 1/2"
T-400-5C	"U" Series Collet – 3/4"
T-400-6C	"U" Series Collet – 1"
T-400-10	Spacer Ring – Black
T-400-11	Spacer Ring – Silver
T-400-62	Spacer Ring – Yellow
T-400-16**	36" T-421U Pump to Press Hose Assembly
T-400-8	Die Ring

\* Pump Required (sold separately): T-421U, T421U-110, T-402-2 or T-403-2 see pages N-33-35.

\*\*Not supplied when ordering a T-402 or T-403 package.

## T-402 • C-O-C I and Air/Hydraulic Pump Package

Includes one each of the following:

Catalog Number	Description
T-400	Press and tooling package/Less T-400-16
T-402-2	Air/Hydraulic Pump
T-400-18	108" Hose assembly and fittings

## T-403 • C-O-C I and Hand Pump Package

Includes one each of the following:

Catalog Number	Description
T-400	Press and tooling package/Less T-400-16
T-403-2	Hand Pump
T-400-19	60" hose assembly and fittings

## T-414 • C-O-C I and 12v Electric Pump Package

Includes one each of the following:

Catalog Number	Description
T-400	Press and tooling package
T-412	12-volt DC Electric Pump

# Crimping Machines - Stationary

Coll-O-Crimp T-400 & T-407

## T-400-9 • Crimp Locator

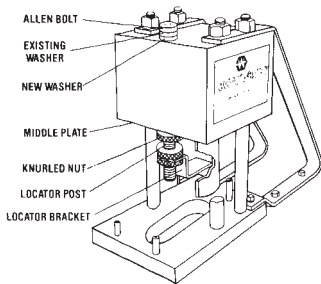

The T-400-9 allows you to make large volumes of hose assemblies by automatically aligning hose ends in proper crimp location.

### Note:

Remove locator assembly when crimping bent tube ends.

## Installation Procedure

- Remove the front Allen bolt using an Allen wrench or tool provided with kit.
- Add the washer provided with the kit to existing washer as shown and torque the bolt down to 75 ft.-lbs.
- Attach the locator post of the pre-assembled locator to the bottom of the middle plate and lock it in place with one of the knurled nuts.
- Align the dimples on the first assembly with top of collet to locate the crimp. Drop the locator bracket down to rest on top of the

hose end. Lock the bracket in position with remaining two knurled nuts. The locator now can be used, instead of dimples, to locate crimp accurately and consistently on the remaining hose ends of the same size and type.

## T-400-1 Coll-O-Crimp I Repair and Replacement Items

Catalog Number	Description
T-400-B	Pusher Bolt
T-400-BB	Switch to interface T400-1 crimper to T421U pump or T-421U-110 pump
T-400-G	1.5 oz. Tube High Efficiency * Grease
T-400-K1	Seal Replacement Kit for T-400-1 press
W-EQCR-TD003-E	Shroud Decal
T-400-M	Instructions for T-400-1
T-400-S	Replacement press shroud with decals.
T-400-8	Die Ring
T-400-13	Replacement** collet cage for T-400 "U" Series collets, 1/4" and 3/8" sizes only, and 229 "P" Series
T-400-14	Replacement** collet cage for T-400 "U" Series collets with a "C" suffix, 1/2" through 1" only,
T-400-90	Replacement** collet cage for T-400 "E", 069 "E", and "E" Series collets with a "C" suffix.
T-432-15	Pusher
E-EQCR-ME002-E	Instructional Video

\*\* 2 required for each collet

## T-407-1 • Production Coll-O-Crimp Press



\*Removal of crimp locator allows for crimping of 45° and 90° angle hose end configurations.

Reference pages N-2 and N-3 for COC machine and tooling packages, and pages N-26 to N-30 for collet kits and spacer ring details.

The T-407-1 Production Coll-O-Crimp, as its name implies, is at its best in the fast production of straight configuration hose end crimping. Taking advantage of the swiveling bracket which supports the crimper, tooling can be put in place and the press locked in at up to a 90° angle, facilitating quick hose end crimping. A crimp locator is included. When set to position, the crimp locator allows for a preset of the correct crimp location so hose assemblies can be built in volume, with accuracy and precision. The T-407-1 offers crimping capabilities of 3/16"-1-fiber braid through 1-3/8" I.D. 1-wire hose and 1-1/4" I.D. 2-wire hose.

**Weight:** (for press and pump) 198 lbs

**Size Press:** 16-1/4" high, 21-3/4" deep

**Includes one each of the following:**

Catalog Number	Description
T-400-M	Instructions
T-400-8	Die Ring
T-400-9	Crimp Locator
T-400-19	60" hose assembly and fittings

## T-407 • Production Coll-O-Crimp Package

The T-407 comes with a high-volume pump and a foot switch.

**Size Pump:** 26" high, 18" wide  
(Pump is wired for 220v, 1 phase)

**Includes one each of the following:**

Catalog Number	Description
T-407-1	Production C-O-C Press
T-433	Two-Stage Piston Pump and foot switch

**Note:** The T-433 pump which is shipped as part of the T-407 Production Coll-O-Crimp System.

# Crimping Machines - Stationary

Coll-O-Crimp Super I, T-420



Refer to pages A-2 and A-3 and machine operator's manuals for safety information.

## T-420 • Coll-O-Crimp Super I Packages for Z-Series

-4 thru -16 (no -10), one-wire and two-wire

Package Number	ET420-002	ET420-003
Power Source	220V	110V
Contents Press	T-420-1	T-420-1
Hose Assembly	T-410-22	T-410-22
Pump	T-421U	T-421U-110
Adapter Ring	T-420-25	T-420-25
Z-Series Collets*	ET420TP-0001	ET420TP-0001

\* See page N-30

## T-420-N • Coll-O-Crimp Super I - 220V Package T-420N-110 • Coll-O-Crimp Super I - 110V Package

Includes one each of the following (with respective pump):

Catalog Number	Description
T-420-1	Coll-O-Crimp Super I Press and T-420-M Instructions
T-421U or T-421U-110	220v or 110V Electric Pump
T-400-2C	"U" Series Collet- 1/4"
T-400-3C	"U" Series Collet- 3/8"
T-400-4C	"U" Series Collet- 1/2"
T-400-5C	"U" Series Collet- 3/4"
T-400-6C	"U" Series Collet- 1"
T-400-10	Spacer Ring- Black
T-400-11	Spacer Ring- Silver
T-400-62	Spacer Ring Yellow
T-410-22	36" Pump to Press Hose Assembly
T-420-25	Adapter Ring for T-400 Series Collets
T-420-4CN	430 "U" Series Collet- 1/2"
T-420-5CN	430 "U" Series Collet- 3/4"
T-420-6CN	430 'U' Series Collet- 1"
T-420-7CN	430 'U' Series Collet- 1-1/4"



The Coll-O-Crimp Super I is a versatile machine ideal for your shop, factory, construction, and mine locations. Big capacity combined with lever-activated crimping gives you wide coverage and a quick and simple way to make factory-quality hose assemblies.

### Capacity

3/16" I.D. 1 fiber braid through 1-1/4" 6 spiral hose\*; for hose other than 4 and 6 spiral, conversion tooling is required. See page N-36 for details.

\*Will not crimp 4SP/6SP ends

### Mounting

Bench or C-40X cabinet.

See pages N-68-70 for cabinet (not included).

### Size

22" high, 10" wide, 20-1/2" deep

### Weight

210 lbs.



### CAUTION

The Coll-O-Crimp power source has the pressure relief valve set at 4000 to 4200 PSI. Damage to the press will result if higher pressures are used and warranty will be voided.

## ET420-004 Coll-O-Crimp I - 220V Package ET420-005 Coll-O-Crimp I - 110V Package

Both Packages include the following (with respective pump):

Catalog Number	Description
T-420-1	Coll-O-Crimp Super I
T-421U or T-421U-110	220v or 110V Electric Pump
ET400DC-M150S	'Z' Series Collet- 1/4"
ET400DC-M195S	'Z' Series Collet- 3/8"
ET400DC-M230S	'Z' Series Collet- 1/2"
T-420-85C	'Z' Series Collet- 5/8"
T-420-86C	'Z' Series Collet- 3/4"
ET420DC-M380S	'Z' Series Collet- 1"
T-400-10	Spacer Ring- Black
T-400-62	Spacer Ring- Yellow
T-420-80R	Spacer Ring- Black/White
ET1000SR-M190D	Spacer Ring- Light Green
ET420SR-M255A	Spacer Ring- Black/Grey
ET420SR-M495A	Spacer Ring- Brown
T-410-22	36" Pump to Press Hose Assembly
T-420-25	Adapter Ring for T-400 Series Collets
T-420-4CN	430 'U' Series Collet- 1/2"
T-420-5CN	430 'U' Series Collet- 3/4"
T-420-6CN	430 'U' Series Collet- 1"
T-420-7CN	430 'U' Series Collet- 1-1/4"

# Crimping Machines - Stationary

Coll-O-Crimp ET4001



The ET4001 is ideal for factory, high performance machine operations, construction and mine locations. This machine offers the capabilities of crimping all of the crimp-style hose ends Weatherhead offers. With this coverage, this heavy-duty crimper can handle all of your crimping needs.

**Capacity**  
3/16" I.D. 1-fiber braid through 2" 6-spiral hose.

**Mounting**  
Bench or Coll-O-Cart (FF91042)

**Size**  
29" high, 12" wide, 21" deep

**Weight**  
550 lbs.

Reference pages N-2 and N-3 for COC machine and tooling packages, and pages N-26 to N-30 for collet kits and spacer ring details.

**Note:**  
Seal kits for T-410, T-440, ET4000 and ET4001 are not sold separately. Crimpers must be sent in and torqued by Weatherhead.

**Note:**  
ET4000AR-002 Adapter Die Ring required for -20, -24, and -32 size 4SP and 6SP series collets.

## ET4001-004 • Coll-O-Crimp Package

Includes one each of the following:

Catalog Number	Description
ET4001-002	ET4001 Press, Operating Instructions and 140-06741 Switch
ET4001P-001	220v Single Phase Electric Pump
T-410-22	36" Pump to Press Hose Assembly

## ET4001-006 • Coll-O-Crimp Package

Includes one each of the following:

Catalog Number	Description
ET4001-004	Press and Pump Package
T-410-4CN	430 'U' Series Collet – 1/2" I.D.
T-410-5CN	430 'U' Series Collet – 3/4" I.D.
T-410-6CN	430 'U' Series Collet – 1" I.D.
T-410-7CN	430 'U' Series Collet – 1-1/4" I.D.
T-410-8N	430 'U' Series Collet – 1-1/2" I.D.
T-410-9N	430 'U' Series Collet – 2" I.D.

## ET4001-010 • Coll-O-Crimp Package

Includes one each of the following:

Catalog Number	Description
ET4001-004	Machine 220V Pump & Assembly
ET4000AR-002	Adapter Ring
ET4000SR-M215A	Black/Magenta Spacer Ring
ET4000SR-M180A	Black/Purple Spacer Ring
T-440-80R	Black/White Spacer Ring
ET4000DC-6S32	2" 6SP Series Collet
ET4000DC-6S24	1-1/2" 6SP Series Collet
ET4000DC-6S20	1-1/4" 6SP Series Collet
ET4000DC-4S16	1" 4SP Series Collet
ET4001DC-4S12	3/4" 4SP Series Collet

# Crimping Machines - Stationary

Repair and Replacement Parts



Refer to pages A-2 and A-3 and machine operator's manuals for safety information.

## Coll-O-Crimp Super I T-420 Repair and Replacement Items

Catalog Number	Description	Catalog Number	Description
T-420-1M	Micro-Switch for T-420-1 Press	T-420-G	Linkage Assembly
T-420-28	Tool Locator Bracket	T-420-2R	Rack
T-420-B	Pusher Bolt and Washers	T-420-2K	Pinion Shaft Assembly (incl'd T-420-2G, T-420-2R and T-420-2S)
W-EQCR-TE006-E	Shroud Decal	T-420-2S	Replacement Pinion Gear Shaft
T-420-H	Handle	T-420-2G	Replacement Pinion Gear
T-420-L	Light Bulb	T-400-G	1.5 oz. Tube High Efficiency Teflon® Grease
T-420-LA	Light Assembly	T-401-1BC	Threaded Breather Cap for T-421U Pump
T-420-LS	Light Switch	T-421U-BC	Twist Lock Breather Cap for T-421U Pump
W-EQCR-TM004-E	Instructions for T-420-1	140-06745	Pusher Wear Plates includes (1) Left and (1) Right
T-420-P	Pusher Set (2) with Wear Plates and Screws	140-06748	Pusher Wear Plates Screws (1)
T-420-S	Press Shroud with Decals		See pages N-33-35 for replacement pumps.
T-420-26	Insert – Base Plate		Reference pages N-2 and N-3 for COC machine and tooling packages, and pages N-26 to N-30 for collet kits and spacer ring details.
E-EQCR-ME002-E	Instructional Video		Refer to pages A-2 and A-3 and machine operator's manuals for safety information.

Teflon® is a registered trademark of DuPont used under license by Eaton.



T-420



ET4000



ET4001



FF91042  
Coll-O-Cart

## Repair and Replacement Items:

Catalog Number	Description
T-410-26	Base Plate Insert for T-410-1 Machine
T-410-26R	Base Plate Insert for T-440-1 Machine
ET4000AR-001	Base Plate Insert for ET4000 Machine
T-410-28	Tool Locator Bracket Kit for the T-410-1 and T-440-1 Machine
ET4000TP-0001	Tool Locator Bracket Kit for the ET4000 Machine
T-410-P	Pusher Set for T-410-1, T-440-1 and ET4000 Machines (includes wear plates)
T-410-1M	Microswitch for T-410-1, T-440-1 and ET400 Machine
T-421-FP	4 Prong Female Electrical Outlet
T-400-G	1.5 oz. Tube Teflon® Grease
T-410-BB	Pump Switch for T-410-1 Machine
140-06741	Pump Switch for the T-440-1 and ET4000 Machines
ET4000TP-002	Wear Plate Kit for T-410-1, T-440-1 and ET4000 Machines (Includes both halves plus screws)
W-EQCR-TE007-E	Shroud Decal for T-440-1 Machine
W-EQCR-TE014-E	Shroud Decal for ET4000 Machine
W-EQCR-TE010-E	Owner's Manual for T-440-1 Machine
W-EQCR-TE002-E	Owner's Manual for ET4000 Machine
W-EQCR-TM022-E	Owner's Manual for ET4001 Machine
E-EQCR-ME002-E	Instructional Video
ET4001-011	ET4000 Retrofit: Lengthen tie rods & install new valve & 3-way switch
ET4001-012	ET4000 Retrofit: Lengthen tie rods
ET4001-013	ET4000 Retrofit: Install new valve & 3-way switch
ET4001-014	ET4000 Retrofit: Kit for field installation of new valve & 3-way switch
ET4001C-0017	Gooseneck lamp, magnetic mount
FF91042	Coll-O-Cart for ET4001 or T-420

Teflon® is a registered trademark of DuPont used under license by Eaton.



# Crimping Machines - Variable

ET4020

## ET4020



The ET4020 is a benchtop crimp machine that crimps hydraulic hose assemblies up to 1-1/4" braided and four spiral wire hose. This machine has programmable electronic keypads with 10 presets. These keypads simplify the hose crimping operation by allowing the machine operator to enter a pre-determined setting for a specific hose type and size. The 10 most often used crimp settings can be stored for one-touch retrieval. The machine will automatically crimp to the exact crimp diameter required for that hose type and size. The electronic crimp machine settings eliminate the need

for spacers or shims in the crimping operation.

### Features

- Electronic Programmable Keypad
- 10 Crimp Diameter Presets
- Individual die cages for each hose size

### Benefits

- Easy to electronically enter crimp setting
- Can pre-program 10 most popular crimp settings
- Die cages easily slip in and out of machine

### Dimensions

12.75" Wide x 25.75" Deep x 28.5" High

### Electrical Requirements

115 volt standard, 230 volt available

### Weight

238 lbs.

### Hose Ends:

Z series and 430U series

### Tooling and Crimp Machine Packages

Part Number	Description	Ends Crimped	430U Sizes Crimped	Tooling and Crimp Machine Packages	
				ET4020TP-0003 Z & 430U Tooling Only	ET4020-006 Z & 430U Tooling & Crimper
ET4020-115	Crimp Machine (115V)			0	1
W-EQCR-TM020-E	Operator's Manual			0	1
FT1380-200-M150	Die Cage	Z		1	1
FT1380-200-M180	Die Cage	Z		1	1
FT1380-200-M210	Die Cage	Z and 430U	-6	1	1
FT1380-200-M240	Die Cage	Z		1	1
FT1380-200-M280	Die Cage	Z and 430U	-8 and -10	1	1
FT1380-200-M320	Die Cage	Z and 430U	-12	1	1
FT1380-200-M370	Die Cage	Z		1	1
FT1380-200-M420	Die Cage	Z and 430U	-16	1	1
FT1381-200-M465	Die Cage	Z and 430U	-20	1	1

**Note:** Also available:

ET4020-230 (230V) machine.  
ET1380-2-4 die holders. Consists of 4 plates that attach to the sides of the machine and can hold up to eight die cages. Mounting hardware is included.

# Crimping Machines - Variable

ET4040



ET4040

The ET4040 crimp machine comes with a base so no benchtop is needed. The ET4040 will crimp up to 2" braided and six heavy-spiral hydraulic hose assemblies. This machine has programmable electronic keypads with 10 presets. These keypads simplify the hose crimping operation by allowing the machine operator to enter a pre-determined setting for a specific hose type and size. The 10 most often used crimp settings can be stored for one-touch retrieval. The machine will automatically crimp to the exact crimp diameter required for that hose type and size.

The electronic crimp machine settings eliminate the need for spacers or shims in the crimping operation.

### Features

- Electronic Programmable Keypad
- 10 Crimp Diameter Presets
- 2-piece Master die cage
- Durable, lightweight and low cost die inserts for each size
- Magnetic handle

### Benefits

- Easy to electronically enter crimp setting
- Can pre-program 10 most popular crimp settings
- Die sets easily mount into fixed master die cage

- Top half of master cage slips in and out to allow easy loading of elbows
- Tool mounted die inserts are safer and cleaner
- Magnetic handle firmly connects & releases die inserts with a quick twist

### Dimensions

29" Wide x 28" Deep x 45" High

### Electrical Requirements

115 volt standard, 230 volt available

### Weight

825 lbs.

### Hose Ends:

Z series, 430U series and 4SP/6SP series

## ET4040 Tooling And Crimp Machine Packages (Qty per package)

Package Part Number	ET4040TP-0004	ET4040-007	ET4040TP-0005	ET4040-008	ET4040TP-0006	ET4040-009		
Part Number	Description	Ends Crimped	Z & 430U Tooling Only	Z & 430U Tooling & Crimper	4SP/6SP Tooling Only	4SP/6SP Tooling & Crimper	Z, 430U, & 4SP/6SP Tooling Only	Z, 430U, & 4SP/6SP Tooling & Crimper
ET4040-115	Crimp Machine (115V)			1		1		1
W-EQCR-TM021-E	Operator's Manual			1		1		1
ET1295-001	Master Die Cage (2-Piece)			1		1		1
ET1295TP-0001	Handle To Capture Die Inserts			1		1		1
ET1295C-0027	Hanging Rack for Die Inserts			2		2		2
ET1295DC-M150S	Die Inserts (8 Pieces)	Z	1	1			1	1
ET1295DC-M180S	Die Inserts (8 Pieces)	Z	1	1			1	1
ET4040DC-M210S	Die Inserts (8 Pieces)	Z and 430U	1	1			1	1
ET1295DC-M240S	Die Inserts (8 Pieces)	Z	1	1			1	1
ET4040DC-M280S	Die Inserts (8 Pieces)	Z and 430U	1	1			1	1
ET4040DC-M320S	Die Inserts (8 Pieces)	Z and 430U	1	1			1	1
ET1295DC-M370S	Die Inserts (8 Pieces)	Z	1	1			1	1
ET4040DC-M420S	Die Inserts (8 Pieces)	Z and 430U	1	1			1	1
ET4040DC-M465S	Die Inserts (8 Pieces)	Z and 430U	1	1			1	1
ET4040DC-M520S	Die Inserts (8 Pieces)	430U	1	1			1	1
ET1295DC-M550S	Die Inserts (8 Pieces)	Z	1	1			1	1
ET4040DC-M570S	Die Inserts (8 Pieces)	Z and 430U	1	1			1	1
ET4040DC-M690S	Die Inserts (8 Pieces)	Z and 430U	1	1			1	1
ET1295DC-82S	Die Inserts (8 Pieces)	4SP12			1	1	1	1
ET1295DC-46S	Die Inserts (8 Pieces)	4SP16			1	1	1	1
ET1295DC-14S	Die Inserts (8 Pieces)	4SP20			1	1	1	1
ET1295DC-20S	Die Inserts (8 Pieces)	4SP24			1	1	1	1
ET1295DC-23S	Die Inserts (8 Pieces)	4SP32			1	1	1	1
ET1295DC-15S	Die Inserts (8 Pieces)	6SP20			1	1	1	1
ET1295DC-16S	Die Inserts (8 Pieces)	6SP24			1	1	1	1
ET1295DC-21S	Die Inserts (8 Pieces)	6SP32			1	1	1	1
MSDS Sheet	Hydraulic Fluid			1		1		1
MSDS Sheet	Never Seez			1		1		1
FT1289-3-30	Shipping Crate			1		1		1
ET4040-230	Crimp Machine(230V, 50/60H) (optional)							

### ET4040 Master Die Cage and Tooling



Master Die Cage

Die Inserts

Handle to capture die inserts

A - ET1295C-0027 Machine Mounted Die Insert Holder Rack (standard)

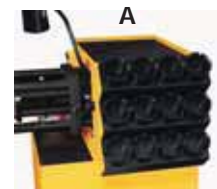

A

B - ET1295C-0029 Table-Top Die Insert Holder Rack (optional)



B

# Coll-O-Crimp Collet Kits

Collet Kits



The Eaton tools listed are offered in kits for any given hose type, or collets and tools can be purchased individually by catalog number.

Refer to Crimp Bulletin # W-HOOV-TM001-E2 for proper spacer rings.



Refer to pages A-2 and A-3 and machine operator's manuals for safety information.

**Note:**

See Crimp Bulletin #W-HOOV-TM001-E2 for proper Collet selection for hose style and size desired.

**Note:**

Collets may be ordered individually.

**T-400-30  
'E' Series Collet Kit**

This kit can be used with the following C-O-C systems: T-400-1, T-420-1, T-440-1, ET4000, T-460, T-462, T-465, and T-480.

**Kit includes one each of the following:**

Catalog Number	Description
T-400-113C	Collet – 3/16" (H243 only)
T-400-31C	Collet – 1/4"
T-400-32C	Collet – 5/16"
T-400-33C	Collet – 3/8"

Spacer Rings not included in T-400-30 kit.

Catalog Number	Description
T-400-34C	Collet – 1/2"
T-400-35C	Collet – 3/4"
T-400-36C	Collet – 1"
FS-1200	Label Set/Layout Guide

**T-400-66  
069 'E' Series  
Collet Kit**

This kit can be used with the following C-O-C systems: T-400-1, T-420-1, T-440-1, ET4000, T-460, T-462, T-465, and T-480.

**Kit includes one each of the following:**

Catalog Number	Description
T-400-54C	Collet – 3/16"
T-400-55C	Collet – 1/4"
T-400-56C	Collet – 5/16"
T-400-57C	Collet – 13/32"
T-400-58C	Collet – 1/2"

Spacer Rings not included in T-400-66 kit.

Catalog Number	Description
T-400-59C	Collet – 5/8"
T-400-60C	Collet – 7/8"
T-400-61C	Collet – 1-1/8"
T-400-70	Collet – 1-3/8"
FS-1500	Label Set/Layout Guide

**T-400-67  
'U' Series Collet Kit**

This kit can be used with the following C-O-C systems: ET1000, T-400-1, T-420-1, T-440-1, ET4000, T-460, T-462, T-465, T-480, and ET1000.

**Kit includes one each of the following:**

Catalog Number	Description
T-400-2C	Collet – 1/4"
T-400-3C	Collet – 3/8"
T-400-4C	Collet – 1/2"
T-400-64C	Collet – 5/8"

Spacer Rings not included in T-400-67 kit.

Catalog Number	Description
T-400-5C	Collet – 3/4"
T-400-6C	Collet – 1"
T-400-12	Collet – 1-1/4"
FS-1100	Label Set/Layout Guide

**T-400-137  
229 'P' Series  
Collet Kit**

This kit can be used with the following C-O-C systems: T-400-1, T-420-1, T-440-1, ET4000, T-460, T-462, T-465, and T-480.

**Kit includes one each of the following:**

Catalog Number	Description
T-400-80C	Collet – 3/16"
T-400-82C	Collet – 13/32"

Spacer Rings not included in T-400-137 kit.

Catalog Number	Description
T-400-81C	Collet – 5/16"
T-400-83C	Collet – 1/2"

**T-400-104  
338 'P' Series  
Collet Kit**

This kit can be used with the following C-O-C systems: T-400-1, T-420-1, T-440-1, ET4000, T-460, T-462, T-465, and T-480.

**Kit includes one each of the following:**

Catalog Number	Description
T-400-102C	Collet – 3/8"
T-400-103C	Collet – 1/2"

Spacer Rings not included in T-400-104 kit.

Catalog Number	Description
FS-2900	Label Set

# Coll-O-Crimp Collet Kits

Collet Kits



**Note:**  
See Crimp Bulletin # W-H00V-TM001-E2 for proper Collet selection for hose style and size desired.



Refer to pages A-2 and A-3 and machine operator's manuals for safety information.

**Note:**  
Collets may be ordered individually.

## T-400-114 757 'E' Series Collet Kit

This kit can be used with the following C-O-C systems: T-400-1, T-420-1, T-440-1, ET4000, T-460, T-462, T-465, and T-480.

**Kit includes one each of the following:**

Catalog Number	Description
T-400-105C	Collet – 5/16"
T-400-107C	Collet – 1/2"

Spacer Rings not included in T-400-114 kit.

Catalog Number	Description
T-400-106C	Collet – 13/32"
T-400-108C	Collet – 5/8"

## T-400-129 336 'E' Series Collet Kit

This kit can be used with the following C-O-C systems: T-400-1, T-420-1, T-440-1, ET4000, T-460, T-462, and T-480.

**Kit includes one each of the following:**

Catalog Number	Description
T-400-120C	Collet – 3/16"
T-400-122C	Collet – 3/8"
T-400-121C	Collet – 1/4"

\* For size 3/4" order T-420-15C. For 1" size order T-420-16C. For use with T-420-1 and T480-1 only.

Catalog Number	Description
T-400-123C	Collet – 1/2"
FS-3500	Label Set

## T-410-70 470 'E' Series Collet Kit

This kit can be used with the following C-O-C systems: T-410-1, T-440-1, ET4000 ONLY.

**Kit includes one each of the following:**

Catalog Number	Description
T-470-8C	Collet – 1/2"
T-470-12C	Collet – 3/4"
T-470-16C	Collet – 1"
T-470-20	Collet – 1-1/4"

\*-32 size requires T-440 or ET4000 system.

Catalog Number	Description
T-470-24	Collet – 1-1/2"
T-440-32*	Collet – 2"
FS-1800	Label Set/Layout Guide

## T-410-80 430 'U' Series No Skive Collet Kit

This kit can be used with the following C-O-C systems: T-440-1, and ET4000 ONLY.

**Kit includes one each of the following:**

Catalog Number	Description
T-410-4CN	Collet – 1/2"
T-410-5CN	Collet – 3/4"
T-410-6CN	Collet – 1"
T-410-7CN	Collet – 1-1/4"

Catalog Number	Description
T-410-8N	Collet – 1-1/2"
T-410-9N	Collet – 2"
FS-3100	Label Set

## T-420-70 470 'E' Series Collet Kit

This kit can be used with the following C-O-C systems: T-420-1, and T-480.

**Kit includes one each of the following:**

Catalog Number	Description
T-420-8C	Collet – 1/2"
T-420-9C	Collet – 3/4"
T-420-10C	Collet – 1"

Catalog Number	Description
T-420-11	Collet – 1-1/4"
FS-1800	Label Set

## T-420-80 430 'U' Series No Skive Collet Kit

This kit can be used with the following C-O-C systems: T-420-1, and T-480

**Kit includes one each of the following:**

Catalog Number	Description
T-420-4CN	Collet – 1/2"
T-420-5CN	Collet – 3/4"
T-420-6CN	Collet – 1"

Catalog Number	Description
T-420-7CN	Collet – 1-1/4"
FS-3100	Label Set

# Coll-O-Crimp Collet Kits

Collet Kits



**Note:**  
See Crimp Bulletin # W-H00V-TM001-E2 for proper Collet selection for hose style and size desired.



Refer to pages A-2 and A-3 and machine operator's manuals for safety information.

**Note:**  
Collets may be ordered individually.

## T-480-80 'U' and 430 'U' Series Collet Kit

This kit can be used with the following C-O-C systems: T-420-1, and T-480 ONLY.

Kit includes one each of the following:

Catalog Number	Description
T-400-2C	Collet – 1/4" 'U' Series
T-400-3C	Collet – 3/8" 'U' Series
T-400-4C	Collet – 1/2" 'U' Series
T-400-5C	Collet – 3/4" 'U' Series
T-400-6C	Collet – 1" 'U' Series
T-400-10	Spacer Ring - Black
T-400-11	Spacer Ring - Silver

Catalog Number	Description
T-400-62	Spacer Ring - Yellow
T-420-25	Adapter Ring for T-400 Series Collets
T-420-4CN	Collet – 1/2" 430 'U' Series
T-420-5CN	Collet – 3/4" 430 'U' Series
T-420-6CN	Collet – 1" 430 'U' Series
T-420-7CN	Collet – 1-1/4" 430 'U' Series

Refer to Crimp Bulletin # W-H00V-TM001-E2 for proper spacer rings.

## 069 'E' Series Collet Size 32

For use with: T-440, and ET4000 ONLY.

Catalog Number	Description
T-410-71C	Collet – 1-13/16"

## 265 'P' Series Collets

For use with: T-400, T-420, T-460, T-462, T-465, T-440, ET4000, T-480.

Kit includes one each of the following:

Catalog Number	Description
T-400-2C	Collet – 1/4" and 3/8"
T-400-3C	Collet – 1/2"

Catalog Number	Description
T-400-64C	Collet – 5/8"

## 4SP & 6SP Series Collets

For use with: T-440. and ET4000 ONLY.

Kit includes one each of the following:

Catalog Number	Description
ET4000DC-4S12	Collet – 3/4"
ET4000DC-4S16	Collet – 1"
ET4000DC-4S20*	Collet – 1-1/4"
ET4000DC-4S24*	Collet – 1-1/2"
ET4000DC-4S32*	Collet – 2"

Catalog Number	Description
ET4000DC-6S20*	Collet – 1-1/4"
ET4000DC-6S24*	Collet – 1-1/2"
ET4000DC-6S32*	Collet – 2"

Qualified on ET4000 machine only.  
\*Requires ET4000AR-002 base adapter bowl.



# Coll-O-Crimp Collet Kits

Collet Kits



Refer to pages A-2 and A-3 and machine operator's manuals for safety information.



**Note:**

See Crimp Bulletin # W-HOOV-TM001-E2 for proper Collet selection for hose style and size desired.

**Note:**

Collets may be ordered individually.

**T-410-27 • Conversion Kit**

For use if you have collets used on our smaller T-400 Coll-O-Crimp I and you are upgrading to an ET4000.

**Example:**

If you desire to crimp hose other than 4- or 6-spiral hose, you will need the T-410-25 Adapter Die Ring which is included in the conversion kit. This ring allows the use of standard Coll-O-Crimp I tooling, in the Coll-O-Crimp II Plus and ET4000 Press.

If you have a Coll-O-Crimp II Plus or ET4000 press and would like to be able to crimp 'U' Series hose ends, order T-410-27 conversion kit and T-400-67 for all the collets. Collets and tools may also be purchased individually by catalog number.

**Kit includes one each of the following:**

Catalog Number	Description
T-410-10	Spacer Ring Black
T-410-11	Spacer Ring Silver
T-410-25	Adapter Die Ring
T-410-41	Spacer Ring Yellow

**Adapter Die Rings**

Catalog Number	Description
T-400-8	Adapter Die Ring for T-400 Collets (T-400-1 Press)
T-410-25	Adapter Die Ring for T-400 Collets (ET4000, T-440-1 Presses)
T-420-25	Adapter Die Ring for T-400 Collets (T-420-1 Press and T-480 Packages)
ET1000AR-001	Adapter Die Ring for T-400 Collets (ET1000 Press)
ET4000AR-002	Adapter Die Ring for-20, -24 & -32 4SP/6SP Ends (ET4000 Press)

**Collet Cage Replacements**

Catalog Number	Description
T-400-13	Replacement collet cages for: T-400-2C, T-400-3C, T-400-80C, T-400-81C, T-400-82C, T-400-83C, T-400-100C, T-400-101C
T-400-14	Replacement collet cages for: T-400-4C, T-400-5C, T-400-6C, T-400-64C, T-400-105C, T-400-106C, T-400-107C, T-400-108C, T-400-109C, T-400-110C, T-400-111C, T-400-120C, T-400-121C, T-400-122C, T-400-123C
T-400-15	Replacement collet cages for: T-400-31C, T-400-32C, T-400-46C, T-400-47C, T-400-102C, T-400-103C, T-400-113C
T-400-90	Replacement collet cages for: T-400-33C, T-400-34C, T-400-35C, T-400-36C, T-400-48C, T-400-49C, T-400-54C, T-400-55C, T-400-56C, T-400-57C, T-400-58C, T-400-59C, T-400-60C, T-400-61C
T-420-14NS	Replacement collet cages for: T-410-4CN, T-410-5CN, T-410-6CN, T-410-7CN, T-410-72CN, T-410-73CN, T-420-4CN, T-420-5CN, T-420-6CN, T-420-7CN
T-420-14	Replacement collet cages for: T-410-4C, T-410-5C, T-410-6C, T-410-7C, T-410-8C, T-420-4C, T-420-5C, T-420-6C, T-420-7C, T-420-8C, T-420-9C, T-420-10C, T-420-30C, T-470-8C, T-470-12C, T-470-16C

**Note:**

These items are half cages. Order 2 for complete cage.

**Die Ring Lubricant**

Catalog Number	Description
T-400-G	1.5 oz. Tube High Efficiency Grease

**Note:**

See page N-31 for individual collet part numbers.



Refer to pages A-2 and A-3 and machine operator's manuals for safety information.

**ET400TP-0001 Crimp Kit for T-400 Crimper**

(For Braided Hose sizes -4 thru 16 (no -10) one-wire and two-wire)

Collet Color	Spacer Ring P/N	Spacer Ring
ET400DC-M150S	ET1000SR-M100A	Purple
ET400DC-M195S	T-400-62	Yellow
ET400DC-M230S	T-400-46R	Black/Tan
ET400DC-M245S	ET1000SR-M190D	Lt. Green
ET400DC-M295S	T-400-37	Green
ET400DC-M375S	T-400-10	Black
	ET400SR-002	Black/Green
	T-400-48R	Black/Orange
	ET400SR-003	Black/Purple
	T-400-49R	Black/Silver
	T-400-112	Tan

Note: Also includes 2 each of ET400AR-001 Adapter Ring.

**ET420TP-0001 Crimp Kit for T-420 Crimper**

(For Braided Hose sizes -4 thru 16 (no -10) for one-wire and two-wire)

Collet Color	Spacer Ring P/N	Spacer Ring
ET400DC-M150S	ET1000SR-M100A	Purple
ET400DC-M195S	T-400-62	Yellow
ET400DC-M230S	T-400-46R	Black/Tan
T-420-86C	ET1000SR-M190D	Lt. Green
ET420DC-M380S	T-400-37	Green
	T-400-10	Black
	T-400-112	Tan
	ET420SR-M495A	Gray
	ET420SR-M255A	Black/Silver
	T-420-29	Orange
	T-420-82R	Black/Blue

**ET440TP-0001 Crimp Kit for T-440, ET4000 and ET4001 Crimpers**

(For Braided Hose sizes -4 thru 16 (no -10) for one-wire and two-wire)

Collet Color	Spacer Ring P/N	Spacer Ring
ET400DC-M150S	ET4000SR-M100A	Purple
ET400DC-M195S	T-410-41	Yellow
ET400DC-M230S	T-440-78R	Black/Tan
T-440-86C	ET4000SR-M190D	Lt. Green
ET4000DC-M380S	T-410-39	Green
	T-410-10	Black
	T-410-42	Tan
	ET4000SR-M405A	Gray
	ET4000SR-M215A	Black/Magenta
	T-410-93	Orange
	T-440-82R	Black/Blue

**ET460TP-0001 Crimp Kit for T-460 Series Crimper**

(For Braided Hose sizes -4 thru 8 one-wire)

Collet Color	Spacer Ring P/N	Spacer Ring
ET400DC-M150S	ET1000SR-M100A	Purple
ET400DC-M195S	T-400-62	Yellow
ET400DC-M230S	T-400-46R	Black/Tan
	ET1000SR-M190D	Lt. Green
	T-400-37	Green
	T-400-10	Black
	T-400-112	Tan

**ET1000TP-0001 Crimp Kit for ET1000 Crimper**

(For Braided Hose sizes -4 thru 16 (no -10) for one-wire and two-wire)

Collet Color	Spacer Ring P/N	Spacer Ring
ET400DC-M150S	ET1000SR-M100A	Purple
ET400DC-M195S	T-400-62	Yellow
ET400DC-M230S	T-400-46R	Black/Tan
T-420-86C	ET1000SR-M190D	Lt. Green
ET420DC-M380S	T-400-37	Green
	T-400-10	Black
	T-400-112	Tan
<b>PUSHER EXTENSION</b>	ET420SR-M495A	Gray
ET1000C-0012	ET420SR-M255A	Black/Silver
	T-420-29	Orange
	T-420-82R	Black/Blue
	T-480-68	Blue

**ET480TP-0001 Crimp Kit for T-480 Crimper**

(For Braided Hose sizes -4 thru 16 (no -10) for one-wire and two-wire)

Collet Color	Spacer Ring P/N	Spacer Ring
ET400DC-M150S	ET1000SR-M100A	Purple
ET400DC-M195S	T-400-62	Yellow
ET400DC-M230S	T-400-46R	Black/Tan
T-420-86C	ET1000SR-M190D	Lt. Green
ET420DC-M380S	T-400-37	Green
	T-400-10	Black
	T-400-112	Tan
	ET420SR-M495A	Gray
	ET420SR-M255A	Black/Silver
	T-420-29	Orange
	T-420-82R	Black/Blue



**Note:**  
See Crimp Bulletin #W-HOOV-TM001-E2 for proper Collet selection for hose style and size desired.

 Refer to pages A-2 and A-3 and machine operator's manuals for safety information.

**'Z' Series Collets**

For use with: T-400, T-410, T-420, T-460, T-462, T-465, T-440, T-480, ET1000, ET4000 and ET4001.

<b>Part Number</b>	<b>Description</b>
ET400DC-M150S	Collet – 1/4"
ET400DC-M195S	Collet – 3/8"
ET400DC-M230S	Collet – 1/2"

**'Z' Series Collets**

For use with: T-400.

<b>Part Number</b>	<b>Description</b>
ET400DC-M245S*	Collet – 5/8"
ET400DC-M295S*	Collet – 3/4"
ET400DC-M375S*	Collet – 1"

\* Requires two ET400AR-001 base halves. Sold separately.

**'Z' Series Collets**

For use with:  
T-420, T-480, and ET1000.

<b>Part Number</b>	<b>Description</b>
T-420-85C	Collet – 5/8"
T-420-86C	Collet – 3/4"
ET420DC-M380S	Collet – 1"
ET420DC-M480S	Collet – 1-1/4" 2-wire (20Z series)
ET420DC-M420S	Collet – 1-1/4" 1-wire (20ZA series)

**'Z' Series Collets**

For use with:  
T-410, T-440, ET4000 and ET4001.

<b>Part Number</b>	<b>Description</b>
T-440-85C	Collet – 5/8"
T-440-86C	Collet – 3/4"
ET4000DC-M380S	Collet – 1"
ET4000DC-M480S	Collet – 1-1/4" 2-wire (20Z series)
ET4000DC-M420S	Collet – 1-1/4" 1-wire (20ZA series)
ET4000DC-M530S	Collet – 1-1/2" H190 hose
ET4000DC-M560S	Collet – 1-1/2" H280 hose
ET4000DC-M550S	Collet – 2" H190 & H280 Hose
ET4000DC-M580S	Collet – 2" H290 hose

# Coll-O-Crimp Spacer Rings

## Spacer Rings



Refer to pages A-2 and A-3 and machine operator's manuals for safety information.



**Note:**

See Crimp Bulletin # W-H00V-TM001-E2 for proper Spacer Ring selection for hose style and size desired.

**Note:**

Spacer rings may ONLY be ordered individually, no sets available.

For use with T-400, T-460, T-462, T-465.

\* T-400 machine only

Catalog Number	Color 5" Diameter	Catalog Number	Color 5" Diameter	Catalog Number	Color 5" Diameter
T-400-10	Black	T-400-45R*	Black/Yellow	ET1000SR-M100A	Purple
T-400-11	Silver	T-400-46R	Black/Tan	ET1000SR-M190D	Lt. Green
T-400-112	Tan	T-400-47R	Black/Red	ET1000SR-M215A	Magenta
T-400-37	Green	T-400-48R*	Black/Orange	ET400SR-001*	Black/Red
T-400-38	Red	T-400-49R	Black/Silver	ET400SR-002*	Black/Green
		T-400-62	Yellow	ET400SR-003*	Black/Purple

For use with T-420.

Catalog Number	Color 5" Diameter	Catalog Number	Color 5" Diameter	Catalog Number	Color 5" Diameter
T-400-10	Black	T-400-47R	Black/Red	ET1000SR-M100A	Purple
T-400-11	Silver	T-400-62	Yellow	ET1000SR-M190D	Lt. Green
T-400-112	Tan	T-420-29	Orange	ET1000SR-M215A	Magenta
T-400-37	Green	T-420-80R	Black/White	ET420SR-M255A	Blk/Grey
T-400-38	Red	T-420-81R	Black/Orange	ET420SR-M495A	Brown
T-400-46R	Black/Tan	T-420-82R	Black/Blue	ET420SR-M660A	Pink

For use with T-480.

Catalog Number	Color 5" Diameter	Catalog Number	Color 5" Diameter	Catalog Number	Color 5" Diameter
T-400-10	Black	T-400-62	Yellow	ET1000SR-M100A	Purple
T-400-11	Silver	T-420-29	Orange	ET1000SR-M190D	Lt. Green
T-400-112	Tan	T-420-80R	Black/White	ET1000SR-M215A	Magenta
T-400-37	Green	T-420-81R	Black/Orange	ET420SR-M255A	Blk/Grey
T-400-38	Red	T-420-82R	Black/Blue	ET420SR-M495A	Brown
T-400-46R	Black/Tan	T-480-68	Blue	ET420SR-M660A	Pink
T-400-47R	Black/Red	ET1000C-0012	Blue		

For use with T-410, T-440, ET4000.

Catalog Number	Color 5" Diameter	Catalog Number	Color 5" Diameter	Catalog Number	Color 5" Diameter
T-410-10	Black	T-410-93	Orange	ET4000SR-M180A	Blk/Purple
T-410-11	Silver	T-440-78R	Black/Tan	ET4000SR-M050A	Blk/Green
T-410-12	White	T-440-79R	Black/Red	ET4000SR-M560A	Pink
T-410-39	Green	T-440-80R	Black/White	ET4000SR-M100A	Purple
T-410-40	Red	T-440-81R	Black/Orange	ET4000SR-M405A	Brown
T-410-41	Yellow	T-440-82R	Black/Blue	ET4000SR-M345A	Blk/Brown
T-410-42	Tan	ET4000SR-M215A	Blk/Magenta	ET4000SR-M190D	Lt. Green

For use with ET1000.

Catalog Number	Color 5" Diameter	Catalog Number	Color 5" Diameter	Catalog Number	Color 5" Diameter
T-400-10	Black	T-400-62	Yellow	ET1000SR-M100A	Purple
T-400-11	Silver	T-420-80R	Black/White	ET1000SR-M190D	Lt. Green
T-400-37	Green	T-420-81R	Black/Orange	ET1000SR-M215A	Magenta
T-400-46R	Black/Tan	T-420-82R	Black/Blue	ET420SR-M255A	Blk/Grey
T-400-47R	Black/Red	ET1000C-0012	Blue	ET420SR-M495A	Brown
				ET420SR-M660A	Pink

# Coll-O-Crimp Pumps

## T-481-110 Electric Pump (110 volt)

For use with  
T-480-EP,  
ET10000.



### Pump Specifications

#### Dimensions

14-14" High x 9-5/8" long x  
9-5/8" wide

#### Weight

32 lbs.

#### Operation Pressure

0-10,000 psi

#### Hydraulic Oil

Use Enerpac Oil ONLY

## T-482-2 Air/Hydraulic Pump

For use with  
T-480-AH,  
ET1000

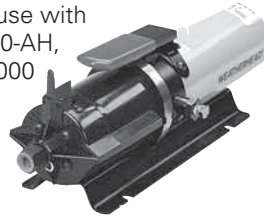

### Pump Specifications

#### Dimensions

5" High, 14-5/8" long, 5-5/8"  
wide

#### Weight

12 lbs.

#### Operation Pressure:

0-10,000 psi

#### Hydraulic Oil

Use Enerpac Oil ONLY

## T-433 Two-Stage Piston Pump (220v)

For use with T-407 Production  
Press, T-400-1  
or T-420-1.

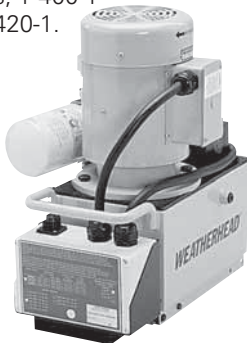

The Weatherhead T-433 two stage piston pump power unit is a high capacity pump especially suited for the T-407 Production crimper. It features a two stage piston pump providing high flow at low pressure for fast ram approach and low flow at high pressure for actual crimping. When used in conjunction with the T-433-2 connector cable, the T-433 can be used as an optional high capacity pump for the T-400-1 or T-420-1 Coll-O-Crimp presses.

### Pump Specifications

#### Dimensions

22" high, 12" long, 15" long

#### Weight

127 lbs.

#### Operation Pressure

4,000 PSI

#### Reservoir Capacity

2 gallons

#### Outlet Port Size

3/8" Pipe Thread

#### Motor

1-1/2" H.P., 220 volts 60hz  
single phase

### Hydraulic Oil

Use Enerpac Oil ONLY

### Flow

2.78 GPM @ 800 PSI, 0.52  
GPM @ 4000 PSI

### Replacement Parts

**T-421-FP** 220v 4 wire Female  
electrical receptacle.

**T-433-1** Foot Switch Assembly

## T-402-2 Air/Hydraulic Pump

For use with T-400-1.

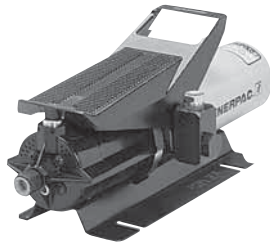

### Pump Specifications:

#### Dimensions:

5-1/4" high, 12-1/2" long,  
5" wide

#### Weight: 18 lbs.

#### Operation Pressure:

4000-4200 PSI

#### Reservoir Capacity: 1 pint

### Hydraulic Oil

Use Enerpac Oil ONLY

### Outlet Port Size

3/8" NPT

### Inlet (Air) Port Size

1/4" NPT

### Inlet Air Pressure Required

60 to 120 PSI

### Note:

It is recommended that a filter, regulator, lubricator, and air pressure gauge be installed in the air line as close as possible to the pump. Filter, Regulator, and Lubricator units not included.

Some models have air port on right side.

## T-403-2 Hand Pump

For use with T-400-1.



### Pump Specifications:

#### Dimensions

7 high, 21" long, 4-3/4" wide

#### Weight

9 lbs.

#### Operation Pressure:

4000-4200 PSI

#### Reservoir Capacity

1 qt.

### Outlet Port Size

3/8"

### NPT Hydraulic Oil

Use Enerpac Oil ONLY

For repair and replacement items for the following pumps please contact an Enerpac Distributor at [www.enerpac.com](http://www.enerpac.com): T-402-2, T-403-2, T-481-110 & T-482-2.



# Coll-O-Crimp Pumps

## T-412 • Mobile Electric Pump

For use with T-400-1.



### Pump Specifications:

**Dimensions:** 7-1/2" high, 14-1/2" long, 9" wide

**Weight:** 65 lbs.

**Operation Pressure:** 4000-4200 PSI

**Reservoir Capacity:** 3 quarts

**Outlet Port Size:** 3/4"-16 straight thread

**Motor:** 2 volt D.C.

### Replacement Parts:

Catalog Number	Description
T-401-1B	Replacement Gasket between motor and square reservoir
T-401-1BC	Breather Cap for Fenner-Stone pumps

**Hydraulic Oil:** SAE 10W hydraulic oil or (ATF) Automatic Transmission Fluid

**Flow:** 0.5 GPM

## T-421U Electric Pump (220 Volt)

For use with T-400-1 and T-420-1.

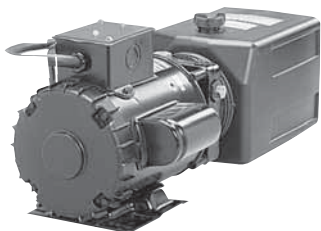

### Pump Specifications:

**Dimensions:** 7-1/2" high, 22" long, 10" wide

**Weight:** 75 lbs.

**Operation Pressure:** 4000-4200 PSI

**Reservoir Capacity:** 6 quarts

**Outlet Port Size:** 3/4"-16 Straight Thread

**Motor:** 1 H.P., 3450 R.P.M., 220 volts, 60 cycle, single phase  
At 50 Hertz, RPM = 2,850  
At 60 Hertz, RPM = 3,450

**Hydraulic Oil\*:** ISO 32 hydraulic oil or (ATF) automatic transmission fluid

\*For low temperature applications automatic transmission fluid can be substituted.

**Flow:** 2.5 GPM @ 750 PSI, 0.5 GPM @ 4000 PSI

### Note:

It is recommended that the electric pump be used on a 15 amp. fused circuit. Pump wired for 220 volts, single phase.

### Replacement Parts:

Catalog Number	Description
140-06761	Relay for T-421U, T-441 and T-441 pumps only
T-421U-BC	Breather Cap - twist lock
T-421-FP	220v 4 wire Female electrical receptacle
T-401-1BC	Breather Cap → threaded

## T-421U-110 Electric Pump (110 Volt)

For use with T-400-1 and T-420-1.

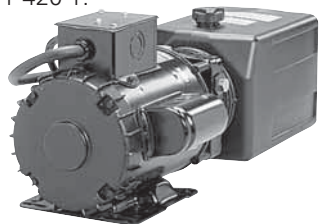

For dimensional data other than voltage information, refer to T-421U see above.

**Note:** It is recommended that the electric pump be used on an individual 30 amp. fused circuit.

Pump wired for 110 volts, single phase.

Assembly Equipment

## T-441 Electric Pump (220 Volt)

For use with T-440-1 and ET4000 only.

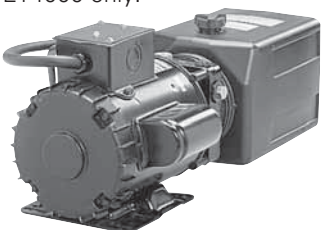

The Weatherhead T-441 power unit is designed for use with the latest Coll-O-Crimp II Plus press. It features a two-stage pump providing high flow at low pressure for fast ram approach and low flow at high pressure for actual crimping.

### Pump Specifications:

**Dimensions:** 7-1/2" high, 22" long, 10" wide

**Weight:** 75 lbs.

**Operation Pressure:** 5,000 PSI

**Reservoir Capacity:** 6 quarts

**Outlet Port Size:** 3/4"-16 Straight Thread O-Ring

**Motor:** 1 H.P., 3450 R.P.M., 220 volts, 60 cycle, single phase

**Hydraulic Oil:** ISO 32 hydraulic oil automatic transmission fluid

**Flow:** 2.5 GPM @ 750 PSI, 0.5 GPM @ 5000 PSI

### Replacement Parts:

T-421U-BC	Breather Cap
T-421-FP	220v 4 wire Female electrical receptacle.
140-06761	Relay for T-421U or T-421U-110 pumps

### Note:

T441 pump is to be used with T440-1 and ET4000 press only. When replacing the pump on a standard T-410 Coll-O-Crimp II Press (without the black switchbox on the side of the press) refer to the repair and replacement items on page N-23.)

# Coll-O-Crimp Pumps

## T-460-2 Hand Pump

For use with T-450-1, T-460 and T-465



### Pump Specifications

**Dimensions**  
5-5/8" High, 13-1/4" long,  
3-3/4" wide

**Weight**  
4-1/2 lbs.

**Operation Pressure**  
0-10,000 PSI

**Reservoir Capacity**  
20 cu in.

**Relief Valve Setting**  
10,000 PSI

**Hydraulic Oil:**  
Use Enerpac Oil ONLY

**Note:**  
For repair and replacement items for the following pumps please contact an Enerpac Distributor at [www.enerpac.com](http://www.enerpac.com):

T-402-2, T-403-2, T-433, T-460-2, T-462-2, T-480-2, T-480-3, T-481-110 & T-482-2.

## T-462-2 Air/Hydraulic Pump

For use with T-462.

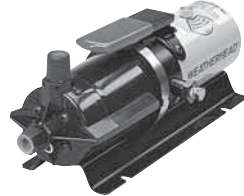

The Weatherhead T-462-2 power unit is a air/hydraulic pump designed for use with the T-462 portable system. Ideal if you have the availability of compressed air in your shop or in the field via a portable compressor.

### Pump Specifications

**Dimensions**  
4" high, 13" long

**Weight**  
8 lbs.

**Operation Pressure**  
0-10,000 PSI

**Reservoir Capacity**  
10 cu in.

**Relief Valve Setting**  
10,000 PSI

**Hydraulic Oil**  
Use Enerpac Oil ONLY

Regulator to be set for 100-120 PSI inlet air.

## Repair and Replacement Items for Discontinued T-401-1 Pump

Catalog Number	Description
T-401-1BC	Breather Cap for Fenner-Stone pumps
T-401-1S	Toggle Switch
T-401-SVF	Shuttle Valve for Fenner-Stone pump

## T-480-2 Two-Stage Hand Pump

For use with T-480-HP, ET1000



### Pump Specifications:

**Dimensions**  
7-3/16" high x 21-1/64" long x 4-3/4" wide

**Weight**  
9 lbs.

**Operation Pressure**  
0-10,000 PSI

**Hydraulic Oil**  
Use Enerpac Oil ONLY

## T-480-3 Turbo Air/Hydraulic Pump

For use with T-480-TA.



### Pump Specifications

**Dimensions**  
8-1/4" High x 12-3/8" long x 8" wide

**Weight**  
16-1/2 lbs.

**Operation Pressure**  
0-10,000 PSI

**Hydraulic Oil:**  
Use Enerpac Oil ONLY

For repair and replacement items for the following pumps please contact an Enerpac Distributor at [www.enerpac.com](http://www.enerpac.com):

T-402-2, T-403-2, T-460-2, T-462-2, T-480-2, T-480-3, T-481-110 & T-482-2.

## T-421-FP 4-Prong Female Electrical Outlet

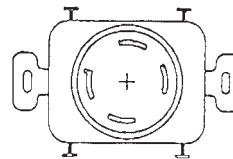

All Weatherhead 220v Coll-O-Crimp power pumps are equipped with a four prong electrical outlet as illustrated.

To obtain corresponding female wall receptacle order T-421-FP. For use with T-421U, T-441 & T-433 pumps.

# Tooling - Competitor Conversion Kits

Conversion Tooling



Refer to pages A-2 and A-3 and machine operator's manuals for safety information.

## T-400-NP60 Dayco to Weatherhead Conversion Kit



The T-400-NP60 Conversion Kit is designed to allow the use of standard Weatherhead Coll-O-Crimp tooling, hose, and hose ends in the Dayco NP60, (2) tie rod, crimp machine. Everything is included to convert the crimper to accept Weatherhead tooling. This kit gives the crimper capacity to crimp up to and including 1-1/4" I.D. 4-spiral wire hose assemblies.

### T-400-NP60 Kit Includes:

Part Description	Qty
Base Plate Assembly	1
Dayco Pusher Spacer	1
3/8-16 x 1.75 Cap Screw	1
Adapter Ring for T-400 Collets	1
Instruction Kit	1

## T-400-DE60 Dayco to Weatherhead Conversion Kit



See pages N-26-32 for collets and spacer rings.

The T-400-DE60 Conversion Kit is designed to allow the use of standard Weatherhead Coll-O-Crimp tooling, hose and hose ends in the Dayco DE60, (4) tie rod, crimp machine. Everything is included to convert the crimper to accept Weatherhead tooling. This kit gives the crimper capacity to crimp up to and including 1-1/4" I.D. 4-spiral wire hose assemblies.

### T-400-DE60 Kit Includes:

Part Description	Qty
Base Plate Assembly	1
Dayco Pusher Spacer	1
3/8-16 x 1.75 Cap Screw	1
Adapter Ring for T-400 Collets	1
Instruction Kit	1

## T-400-GT Gates PC707 Conversion Kit



The T-400-GT Conversion Kit is designed to allow the use of standard Weatherhead Coll-O-Crimp tooling, hose, and hose ends in the Gates PC707 crimper. Everything is included to convert the crimper to accept Weatherhead tooling. This kit gives the crimper capacity to crimp up to and including 1-1/4" I.D. 2-wire hose factory-type hose assemblies. **This kit does not include the T-400-8 Die Ring which is required for crimping.** If you do not already have the die ring or collets, you can order the kit to the right.

### T-400-GT kit includes:

Pusher, 10-24 x 1/4 Set Screws (2), Spacer (2), Instructions

### T-400-GTK • Gates PC707 Conversion Kit

Kit includes one each of the following:

Catalog Number	Description
T-400-GT	Conversion Kit
T-400-2C	'U' Series Collet – 1/4"
T-400-3C	'U' Series Collet – 3/8"
T-400-4C	'U' Series Collet – 1/2"
T-400-5C	'U' Series Collet – 3/4"
T-400-6C	'U' Series Collet – 1"
T-400-8	Die Ring – 3/16" thru 1-1/4"
T-400-10	Spacer Ring – Black
T-400-11	Spacer Ring – Silver

## T-400-PH Parker 80c Conversion Kit

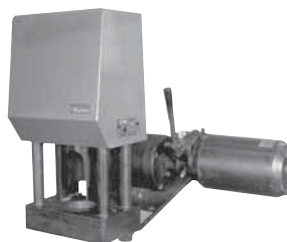

The T-400-PH Conversion Kit is designed to allow the use of standard Weatherhead Coll-O-Crimp tooling, hose, and hose ends in the Parker 80c crimper. Everything is included to convert the crimper to accept Weatherhead tooling. This kit gives the crimper capacity to crimp up to and including 1-1/4" I.D. 2-wire hose factory-type hose assemblies. If you do not already have the collets and spacer rings, you can order the kit to the right.

### T-400-PH Kit includes:

1/4-20 x 1 Cap Screw (4), Dowel Pin Spacer (2), 1/4" Lockwasher (4), Spacer Bracket (4), Adapter Die Ring, Instructions

### T-400-PHK • Parker 80c Conversion Kit

Kit includes one each of the following:

Catalog Number	Description
T-400-PH	Conversion Kit
T-400-2C	'U' Series Collet – 1/4"
T-400-3C	'U' Series Collet – 3/8"
T-400-4C	'U' Series Collet – 1/2"
T-400-5C	'U' Series Collet – 3/4"
T-400-6C	'U' Series Collet – 1"
T-400-10	Spacer Ring – Black
T-400-11	Spacer Ring – Silver

# Tooling

## Tube Flaring Tools

### T-1290 • Segmented Flaring Tool (37°)

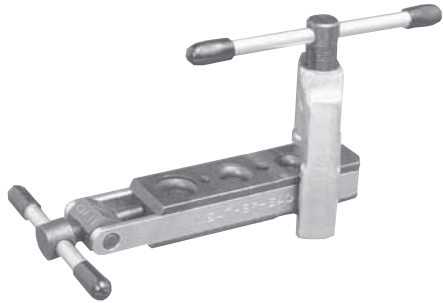

Hard chrome-finished cone makes exceptionally smooth flares and minimizes amount of effort needed. Forged steel yoke for maximum strength. Sliding die blocks lock in place by lever clamp action.

#### Flaring Capacity

3/16", 1/4", 5/16", 3/8", 1/2" and 5/8" O.D. Forms 37° SAE flares in soft copper, aluminum, brass, and Bundyweld tubing.

#### Weight

1 lb., 11 oz.

### T-1295 • Heavy-Duty Segmented Flaring Tool (37°)

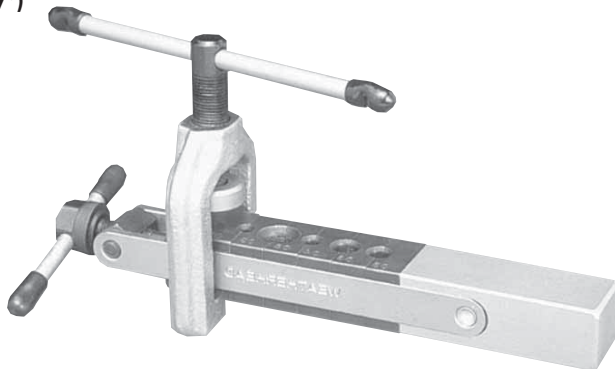

Ideal for use where considerable number of 37° flares in stainless steel tubing must be made. Built to withstand continuous rugged service. Ball thrust mechanism reduces effort required. Hardened tool steel die features non-slip grip of tubing – even after repetitive flaring. Bar has vise extension.

#### Flaring Capacity

1/8", 3/16", 1/4", 5/16", 3/8", and 1/2", O.D. tubing. Forms 37° SAE flares in annealed stainless steel (MIL-T-6845 or AMS-5566), cold drawn stainless steel, and annealed copper, brass, steel, or aluminum.

#### Weight

3 lbs.

# Tooling

## Hose Cutting Equipment

 Refer to safety information regarding Coll-O-Crimp hose, hose fittings and assembly equipment compatibility on pages A-2-3.

### T-60A Portable Cutter



An excellent heavy-duty cutting machine. The T-60A is a portable power saw that can cut all hoses, including wire-reinforced. Includes three abrasive blades.

### Replacement Blade T-1060A 14" diameter

**Motor**  
3-1/2 H.P., 110/115 volts

**Amps**  
15 amps

**Weight**  
45 lbs.

**RPM**  
3500

**Note**  
Three blades are mounted on shaft for shipping purposes. Remove prior to use.

### T-10B Hose Cutting Machine



The T-10B hose cutting machine assures quick, clean, right angle cuts, eliminating ragged and frayed cut ends which make hose assembly difficult and are a possible cause of premature hose failure. A powerful 1 H.P. motor and belt-driven blade cut all low, medium, and high pressure fabric and wire-braided hose from 3/16" through 1-1/4" I.D. 2 wire hose. Specifically designed for cutting hose, the T-10B is a natural companion to the T-400-1 Coll-O-Crimp and T-300 hose assembly machines.

### Ordering Options

T-10B= saw with smooth edge blade for cutting up to 1-1/4" 1-wire hose

T-10B-1= saw with scalloped edge blade for cutting up to 1-1/4" 2-wire hose.

**Replacement Blades**  
T-1047 (Smooth)

T-1047-1 (Scalloped)

**Replacement Belt for T-10B & T-10C**  
T-10V-1 Belt

**Motor**  
1 H.P., 3450 RPM, 115, 60 cycle, single phase

**Size**  
13" wide, 24" long, 17" high

**Weight**  
85 lbs.

**Amps Drawn**  
115 volts – 15 amps

**Replacement Parts**  
**T-10-D** Hose/Dowel  
**T-10-H** Handle  
**T-10-P** Pusher



# Tooling

## Hose Cutting Equipment

 Refer to safety information regarding Coll-O-Crimp hose, hose fittings and assembly equipment compatibility on pages A-2-3.

### T-9-1 & T-9-3 Hose Cutting Machine



The T-9-1 and T-9-3 provide the capability for cutting multi-spiral and braided wire-reinforced hose through 2" I.D. Either machine is a perfect companion for the ET4000 press. Includes scalloped blade.

**Note**

The T-9-1 and T-9-3 are shipped less a line cord and plug. An electrician is recommended for direct electrical hook-up.

**T-9-1**

**Motor**

3 H.P., 230 volts, 60 cycle, single phase

**Size**

24" wide, 24" deep, 24" high

**Weight**

Approx. 255 lbs.

**Amps Drawn**

At 230 volts – 17

**T-9-3**

**Motor**

3 H.P., 230 volts, 60 cycle, 3 phase

**Size and Weight**

Same as T-9-1

**Amps Drawn**

At 230 volts – 8 amps

**Replacement Blade:**

**T-75-14** Scalloped

**T-75-17** Carborundum

**T-75-11** Smooth

**Guard**

**T-9-G**

### T-71 Hose Cutting Machine



This cutting machine easily handles all 1 and 2 braided wire hose through 4" I.D., up to 2" I.D. 4-spiral and up to 1-1/2" I.D. 6 multi-spiral reinforced hose. That makes this machine ideal for cutting most hydraulic and pneumatic hoses as well as a variety of industrial fluid transfer hoses. The T-71 uses a 14" cutting blade, T-1070, for cutting all 1 & 2 wire braid and through 2" 4 spiral hose. The scalloped toothed blade T-1071, is for cutting industrial transfer hoses through 4" and the smooth

beveled blade, T-1072, for cutting hose with a wire braid cover. T-71 includes a scalloped blade.

The T-71 is shipped with a scalloped blade, T-1070.

**Replacement Blade**

**T-1070** Steel Scalloped

**T-1071** Steel Scalloped Toothed

**T-1072** Steel Smooth Beveled

**Motor**

4.5 H.P., 110/115 volts, single phase, 60 cycle

**Size**

22" wide, 19" deep, 25" high

**Weight**

Approx. 85 lbs.

**Amps Drawn**

115 volts – 20 amp

### Hose Cutting and Skiving Wheels



Part Number	Type	Blade Dia.	Hole Dia.	Applicable Machinex
<b>Cutting Wheels</b>				
T-1042	Carborundum	8"	5/8"	T-10A
T-1047	Steel Smooth	7"	5/8"	T-10B & T-10C
T-1047-1	Steel Scalloped	7"	5/8"	T-10B & T-10C
T-1060	Carborundum	12"	1"	T-60
T-1060A	Carborundum	14"	1"	T-60A
T-1070	Steel Scalloped	14"	1"	T-70, T-71
T-1071	Steel Scalloped Toothed	14"	1"	T-70, T-71
T-1072	Steel Smooth Beveled	14"	1"	T-70, T-71
T-75-11	Steel Smooth	10"	3/4"	T-9/T-75
T-75-14	Steel Scalloped	10"	3/4"	T-9/T-75
T-75-17	Carborundum	10"	3/4"	T-9/T-75
<b>Skiving Wheels</b>				
T-75-12	Wire	8"	1"	T-75
<b>Belts</b>				
T-76-B	Reinforced	1"		Old T-76/T-76-1